

**I. MATERIALS & FINISHES**

Components	Materials	Finishes	Thk. (μ")
Body	Brass	Albaloy	80
Center Cont.	QBe2	Gold	50
Ferrule	Brass	Albaloy	80
Nut	Brass	Albaloy	80
Insulator	PTFE	--	--
Gasket	Silicone	--	--

**III. ENVIRONMENT PROPERTIES**

Temperature Range:	-40°C~+125°C
Thermal Shock:	MIL-STD 202G, Meth.107, Cond.B
Vibration:	MIL-STD 202G, Meth.204, Cond.B
Shock:	MIL-STD 202G, Meth.213, Cond I
Climatic Class:	IEC 60068 55/155/56
(2002/95/EC)RoHS:	Compliant

**V. TOOLING**

Stripping Tool: 3192-152/CST-240A  
 Crimping Tool: 3190-667/CT-240/200/100

**II. ELECTRICAL PROPERTIES**

Impedance (Ω):	50
Frequency Range (GHz):	DC to 6 GHz
Working Voltage (V):	2500
Insulation Resistance (MΩ):	≥10000
VSWR:	≤1.30
Insertion Loss(dB, f/GHz):	-0.1x √f

**IV. MECHANICAL PROPERTIES**

Center Cont.:	Finger Contact
Outer Cont.:	Crimp
Coupling Nut Torque (N.m):	1.7
Cbl-Connector Retention Force (N):	250
Durability (cycles):	500

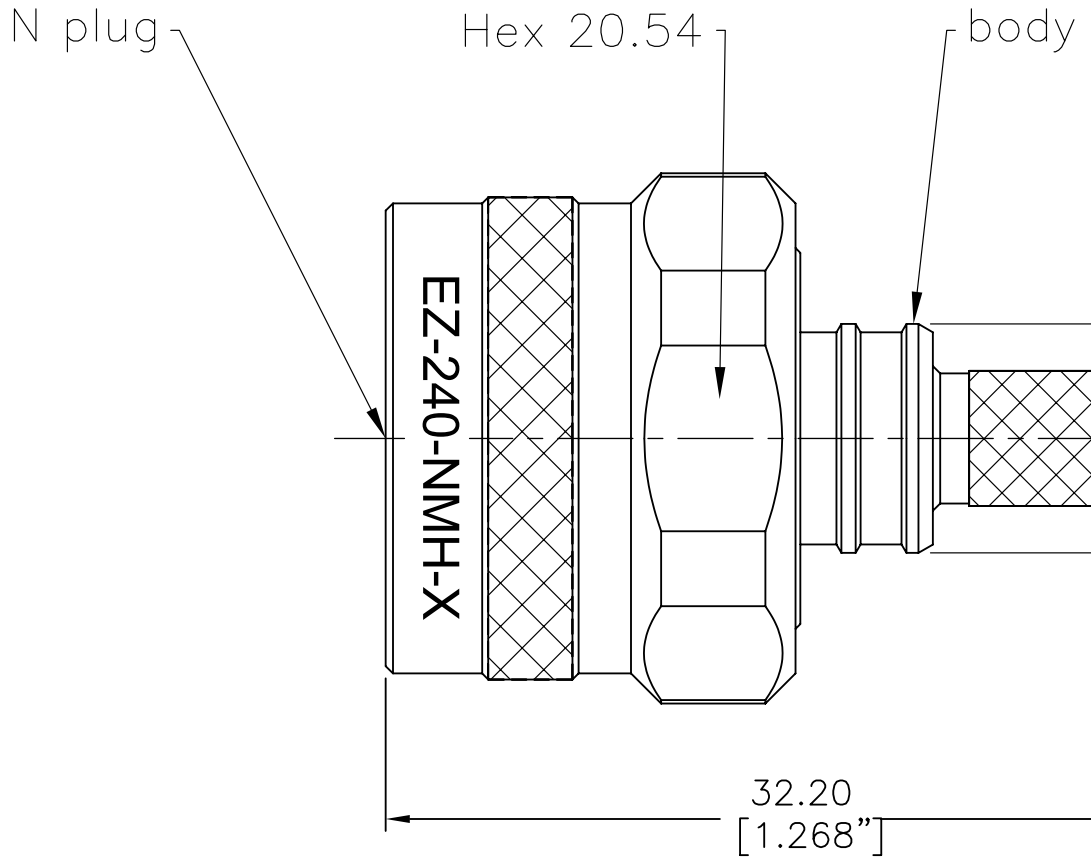

**I. MATERIALS & FINISHES**

Components	Materials	Finishes	Thk. (μ")
Body	Brass	Albaloy	80
Center Cont.	QBe2	Gold	50
Ferrule	Brass	Albaloy	80
Nut	Brass	Albaloy	80
Insulator	PTFE	--	--
Gasket	Silicone	--	--

**III. ENVIRONMENT PROPERTIES**

Temperature Range:	-40°C~+125°C
Thermal Shock:	MIL-STD 202G, Meth.107, Cond.B
Vibration:	MIL-STD 202G, Meth.204, Cond.B
Shock:	MIL-STD 202G, Meth.213, Cond I
Climatic Class:	IEC 60068 55/155/56
(2002/95/EC)RoHS:	Compliant

**V. TOOLING**

Stripping Tool: 3192-152/CST-240A  
 Crimping Tool: 3190-667/CT-240/200/100

**II. ELECTRICAL PROPERTIES**

Impedance (Ω):	50
Frequency Range (GHz):	DC to 6 GHz
Working Voltage (V):	2500
Insulation Resistance (MΩ):	≥10000
VSWR:	≤1.30
Insertion Loss(dB, f/GHz):	-0.1x √f

**IV. MECHANICAL PROPERTIES**

Center Cont.:	Finger Contact
Outer Cont.:	Crimp
Coupling Nut Torque (N.m):	1.7
Cbl-Connector Retention Force (N):	250
Durability (cycles):	500



## LMR-LW240 Light weight version of the 240 series Low Loss Coax

### Times Microwave Systems Coax Cable Specification

#### Configuration

- Low Loss, Outdoor Flexible Cable
- 2 Shield(s)

#### Features

- Light Weight Coax with Aluminum Shielding
- Max Operating Frequency of 8 GHz
- Phase Velocity 83% VoP
- Max Operating Temperature +85°C
- PE Jacket
- Min Install Bend Radius of 0.75 inches

#### Applications

- Antenna Installs
- RF Test Systems
- General Purpose RF Interconnect
- Laboratory Applications

#### Description

LMR-LW240 Light weight version of the 240 series Low Loss Coax from Times Microwave is part of the large product offering by Pasternack of radio frequency coaxial cable types specifically stocked to be ready for same-day shipment. Pasternack LMR-LW240 coax cable is manufactured in a flexible design and has a 50 Ohm impedance. This low loss and light weight flexible 50 Ohm coax cable LMR-LW240 is constructed with a 0.240 inch diameter and Black PE jacket.

LMR-LW240 flexible 50 Ohm coax cable with PE jacket is rated for a 8 GHz maximum operating frequency. This 50 Ohm 0.240 inch diameter and low loss flexible coax cable is built with an aluminum double shield count and RF shielding of 90 dB. Times Microwave LMR-LW240 PE coax is constructed with Foam PE dielectric and a maximum operating temperature of 85 degrees C. Pasternack's offering of LMR-LW240 coax cable provides specs for this wire on its RF coax cable LMR-LW240 datasheet.

LMR-LW240 cable is part of more than one million RF, microwave parts in stock at Pasternack. This Times Microwave low loss and light weight LMR-LW240 coax cable is ready to buy and can be shipped worldwide. Pasternack also maintains a wide selection of other radio frequency coaxial cable types that ship same-day from our warehouse as with the rest of our other RF/microwave components.

\* LMR™ is a trademark of Times Microwave Systems.

#### Electrical Specifications

Description	Minimum	Typical	Maximum	Units
Frequency Range	DC		8	GHz
Impedance		50		Ohms
Velocity of Propagation		83		%
Time Delay		1.21 [3.97]		ns/ft [ns/m]
Shielding Effectiveness	90			dB
Dielectric Withstanding Voltage (DC)			1,500	Vdc
Jacket Spark			5,000	Vrms

Click the following link (or enter part number in "SEARCH" on website) to obtain additional part information including price, inventory and certifications: [LMR-LW240 Light weight version of the 240 series Low Loss Coax LMR-LW240](#)



## LMR-LW240 Light weight version of the 240 series Low Loss Coax

### RF Cables Technical Data Sheet



LMR-LW240

Inner Conductor DC Resistance	3.2	Ohms/1000ft
Outer Conductor DC Resistance	14.4	Ohms/1000ft
Nominal Capacitance	24.2 [79.4]	pF/ft [pF/m]
Nominal Inductance	0.06 [0.2]	uH/ft [uH/m]
Input Power (Peak)	5.6	kWatts

#### Performance by Frequency Band

Description	F1	F2	F3	F4	F5	Units
Frequency	0.05	0.15	0.45	0.9	1.5	GHz
Attenuation, Typ	1.7	3	5.3	7.6	9.9	dB/100ft
	5.58	9.84	17.39	24.93	32.48	dB/100m
Input Power (CW), Max	1,150	660	380	260	200	Watts

Description	F6	F7	F8	F9	F10	Units
Frequency	1.8	2	2.5	5.8	8	GHz
Attenuation, Typ	10.9	11.5	12.9	20.4	24.3	dB/100ft
	35.76	37.73	42.32	66.93	79.72	dB/100m
Input Power (CW), Max	180	170	150	100	80	Watts

#### Mechanical Specifications

Diameter	0.24 in [6.1 mm]
Weight	0.026 lbs/ft [0.04 kg/m]
Min. Bend Radius (Installation)	0.75 in [19.05 mm]
Min. Bend Radius (Repeated)	2.5 in [63.5 mm]
Bending Moment	0.25 lbs-ft [0.34 N-m]
Tensile Strength	80 lbs [36.29 kg]
Flat Plate Crush	20 lbs/in [0.36 kg/mm]

#### Construction Specifications

Description	Material and Plating	Diameter
Inner Conductor	Copper, 1 Strand	0.056 in [1.42 mm]
Conductor Type	Solid	

Click the following link (or enter part number in "SEARCH" on website) to obtain additional part information including price, inventory and certifications: [LMR-LW240 Light weight version of the 240 series Low Loss Coax LMR-LW240](#)



## LMR-LW240 Light weight version of the 240 series Low Loss Coax

### RF Cables Technical Data Sheet



LMR-LW240

Dielectric	Foam PE	0.15 in [3.81 mm]
First Shield	Aluminum Tape	[ ]
Second Shield	Aluminium	[ ]
Jacket	PE, Black	0.24 in [6.1 mm]

#### Environmental Specifications

##### Temperature

Operating Range	-40 to +85 deg C
Installation Range	-40 to +85 deg C
Storage Range	-70 to +85 deg C

#### Compliance Certifications (see [product page](#) for current document)

#### Plotted and Other Data

Notes:

LMR-LW240 Light weight version of the 240 series Low Loss Coax from Pasternack Enterprises has same day shipment for domestic and International orders. Our RF, microwave and millimeter wave products maintain a 99.4% availability and are part of the broadest selection in the industry.

Click the following link (or enter part number in "SEARCH" on website) to obtain additional part information including price, inventory and certifications: [LMR-LW240 Light weight version of the 240 series Low Loss Coax LMR-LW240](#)

URL: <https://www.pasternack.com/low-loss-flexible-lmr-lw240-pe-jacket-aluminum-tape-over-aluminium-outer-conductor-double-shielded-lmr-lw240-p.aspx>

The information contained in this document is accurate to the best of our knowledge and representative of the part described herein. It may be necessary to make modifications to the part and/or the documentation of the part, in order to implement improvements. Pasternack reserves the right to make such changes as required. Unless otherwise stated, all specifications are nominal. Pasternack does not make any representation or warranty regarding the suitability of the part described herein for any particular purpose, and Pasternack does not assume any liability arising out of the use of any part or documentation.

REVISIONS			
REV.	DESCRIPTION	DATE	APPROVED
A	INITIAL RELEASE	06-04-2021	SELLIS

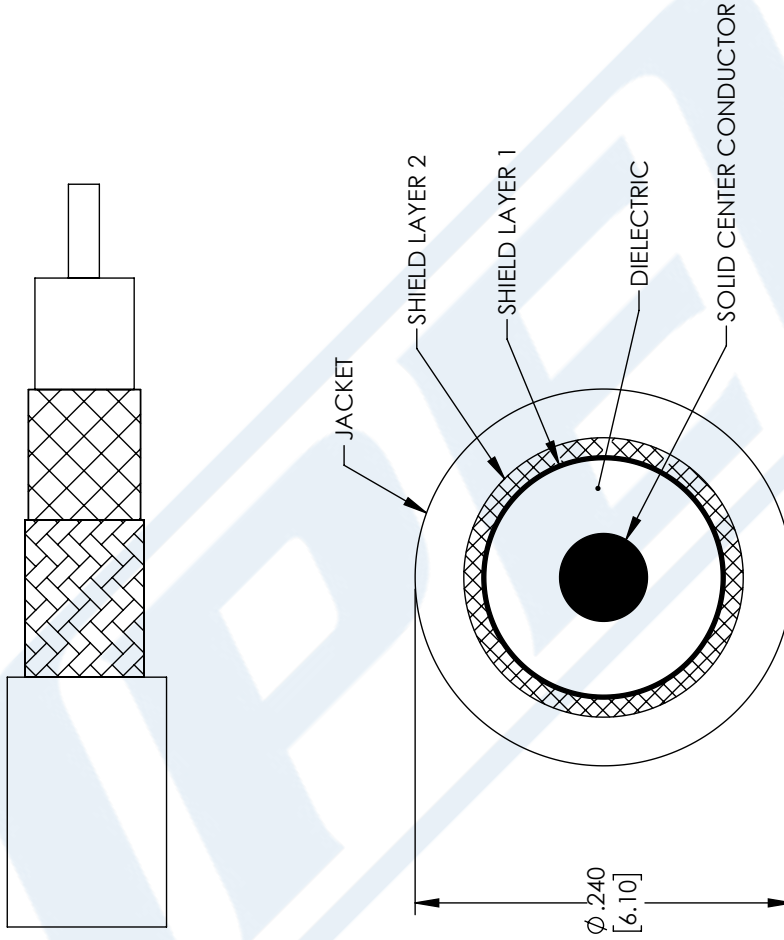

UNLESS OTHERWISE SPECIFIED LEADING DIMENSIONS ARE INCHES DIMENSIONS IN [ ] ARE MILLIMETERS  TOLERANCES: .X = ±.2 [ .008]    FRACTIONS ± 1/32 .XX = ±.02 [ .51]    ANGLES ± 1° .XXX = ±.005 [ .13] CABLE LENGTH (L), TOLERANCES: L ≤ 12 [305] = +1 [25] / -0 12 [305] < L ≤ 60 [1524] = +2 [51] / -0 60 [1524] < L ≤ 120 [3048] = +4 [102] / -0 120 [3048] < L ≤ 300 [7620] = +6 [152] / -0 300 [7620] < L = +5% / -0  ALL DIMENSIONS SHOWN ARE FOR REFERENCE ONLY.	<b>PE PASTERNAK</b> an INFINITI brand  Pasternack Enterprises, Inc. P. O. Box 16759, Irvine, CA 92623. Phone: 1.949.261.1920   1.866.727.8376 Fax: 1.949.261.7451 Website: www.pasternack.com E-mail: sales@pasternack.com	THIRD-ANGLE PROJECTION  THE INFORMATION AND DESIGN IN THIS DOCUMENT IS THE PROPERTY OF PASTERNAK CORPORATION ALL RIGHTS RESERVED. SHEET 1 OF 1 SCALE N/A
	SIZE A CAGE CODE 53919 DRAWN BY MVEERAPPAN ITEM NO. LMR-LW240	REV A

THESE COMMODITIES, TECHNOLOGY OR SOFTWARE WERE EXPORTED FROM THE UNITED STATES IN ACCORDANCE WITH THE EXPORT ADMINISTRATION REGULATIONS. DIVERSION CONTRARY TO U.S. LAW PROHIBITED.