



SMA Male Connector Solder Attachment for PE-SR402AL, PE-SR402FL, PE-SR402FLJ, PE-SR402TN, RG402

## RF Connectors Technical Data Sheet

PE4112

### Configuration

- SMA Male Connector
- MIL-STD-348A
- 50 Ohms
- Straight Body Geometry
- PE-SR402AL, PE-SR402FL, PE-SR402FLJ, PE-SR402TN, RG402 Interface Type
- Solder/Solder Attachment
- 5/16 inch Hex

### Features

- Max. Operating Frequency 18 GHz
- Excellent VSWR of 1.2:1
- Gold Plated Brass Contact
- 50 µin minimum contact plating

### Applications

- General Purpose Test
- Custom Cable Assemblies

### Description

Pasternack's PE4112 SMA male connector with solder/solder attachment for PE-SR402AL, PE-SR402FL, PE-SR402FLJ, PE-SR402TN and RG402 is part of our full line of RF components available for same-day shipping. Our SMA male connector operates up to a maximum frequency of 18 GHz and offers excellent VSWR of 1.2:1.

Our SMA male connector PE4112 datasheet specifications and drawing with dimensions are shown below in this PDF. Pasternack's broad catalog of RF, microwave and millimeter wave connectors allows designers to configure and customize their signal connections however they like. Whether the need is to provide an I/O for a board design, or simply create a custom cable assembly configuration, Pasternack has the right connector for the job. Pasternack can also expertly build your custom cable assemblies for you and ship same-day.

### Electrical Specifications

Description	Minimum	Typical	Maximum	Units
Frequency Range	DC		18	GHz
VSWR			1.2:1	
Operating Voltage (AC)			500	Vrms

### Mechanical Specifications

<b>Size</b>	
Length	0.415 in [10.54 mm]
Width/Dia.	0.315 in [8.00 mm]
Weight	0.01 lbs [4.54 g]
Mating Torque	3 to 5 in-lbs [0.34 to 0.57 Nm]

Click the following link (or enter part number in "SEARCH" on website) to obtain additional part information including price, inventory and certifications: [SMA Male Connector Solder Attachment for PE-SR402AL, PE-SR402FL, PE-SR402FLJ, PE-SR402TN, RG402 PE4112](#)



SMA Male Connector Solder Attachment for PE-SR402AL, PE-SR402FL, PE-SR402FLJ, PE-SR402TN, RG402

## RF Connectors Technical Data Sheet

PE4112

### Material Specifications

Description	Material	Plating
Contact	Brass	Gold 50 µin minimum
Insulation	PTFE	
Body	Stainless Steel	Gold 10 µin minimum
Coupling Nut	Brass	Nickel 100 µin minimum

### Environmental Specifications

#### Temperature

Operating Range

-65 to +165 deg C

**Compliance Certifications** (see [product page](#) for current document)

### Plotted and Other Data

Notes:

SMA Male Connector Solder Attachment for PE-SR402AL, PE-SR402FL, PE-SR402FLJ, PE-SR402TN, RG402 from Pasternack Enterprises has same day shipment for domestic and International orders. Our RF, microwave and millimeter wave products maintain a 99% availability and are part of the broadest selection in the industry.

Click the following link (or enter part number in "SEARCH" on website) to obtain additional part information including price, inventory and certifications: [SMA Male Connector Solder Attachment for PE-SR402AL, PE-SR402FL, PE-SR402FLJ, PE-SR402TN, RG402 PE4112](#)

URL: <https://www.pasternack.com/sma-male-standard-pe-sr402al-pe-sr402fl-rg402-connector-pe4112-p.aspx>

The information contained in this document is accurate to the best of our knowledge and representative of the part described herein. It may be necessary to make modifications to the part and/or the documentation of the part, in order to implement improvements. Pasternack reserves the right to make such changes as required. Unless otherwise stated, all specifications are nominal. Pasternack does not make any representation or warranty regarding the suitability of the part described herein for any particular purpose, and Pasternack does not assume any liability arising out of the use of any part or documentation.

# PE4112 CAD Drawing

SMA Male Connector Solder Attachment for PE-SR402AL, PE-SR402FL, PE-SR402FLJ, PE-SR402TN, RG402

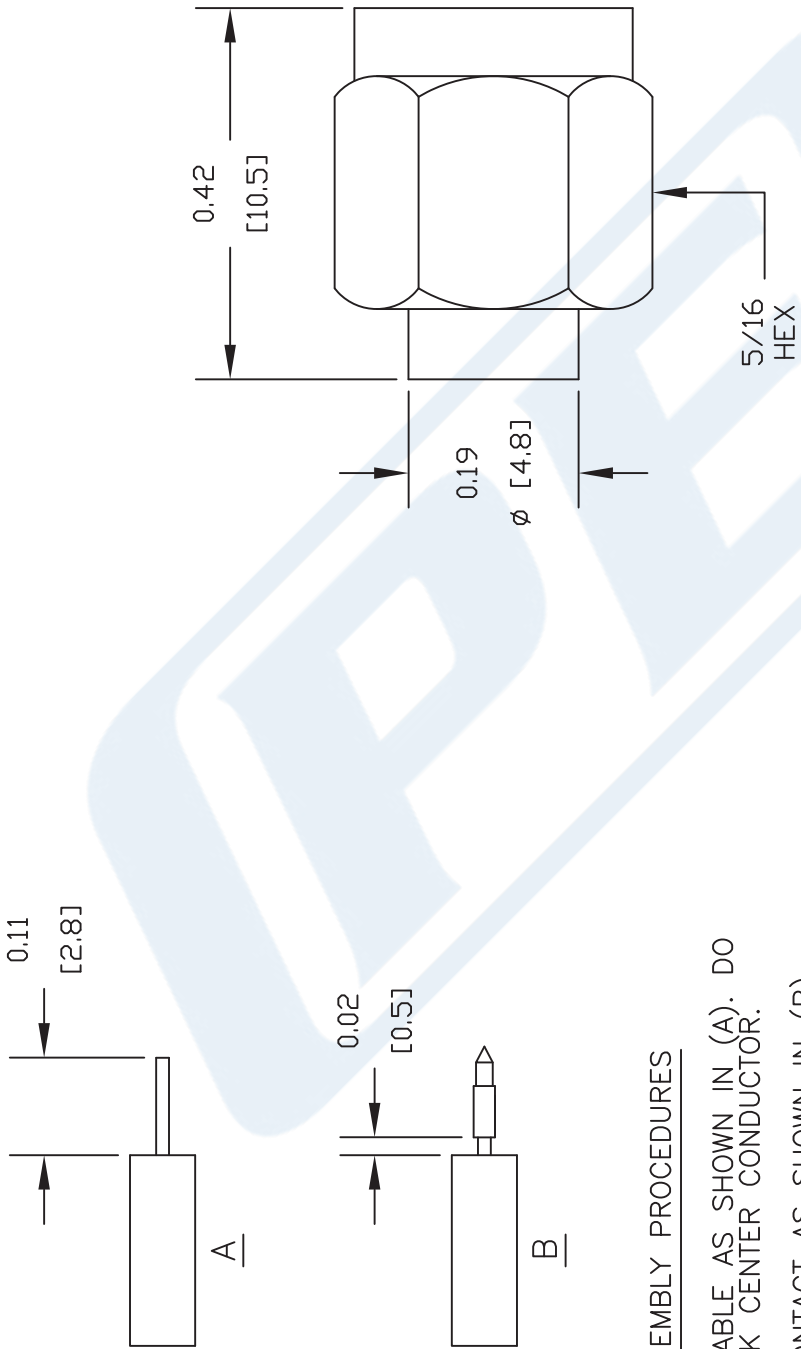

## ASSEMBLY PROCEDURES

1. STRIP CABLE AS SHOWN IN (A). DO NOT NICK CENTER CONDUCTOR.
2. SHIM CONTACT AS SHOWN IN (B) & SOLDER CONTACT TO CENTER CONDUCTOR.
3. INSERT CABLE INTO BODY UNTIL OUTER CONDUCTOR BOTTOMS OUT SOLDER OUTER CONDUCTOR TO BODY.

DWG TITLE

**PE4112**

- NOTES:
1. UNLESS OTHERWISE SPECIFIED ALL DIMENSIONS ARE NOMINAL.
  2. ALL SPECIFICATIONS ARE SUBJECT TO CHANGE WITHOUT NOTICE AT ANY TIME.
  3. DIMENSIONS ARE IN INCHES [mm].
  4. FITS MIL-C-17 AND EQUIVALENT CABLES.

REV. -

FSCM NO. 53919

CAD FILE 120804

SCALE N/A

SIZE A

127



**PASTERNAK®**  
Pasternack Enterprises, Inc.  
P.O. Box 16759 | Irvine | CA | 92623

Phone: (949) 261-1920 | Fax: (949) 261-7451

Website: [www.pasternack.com](http://www.pasternack.com) | E-Mail: [sales@pasternack.com](mailto:sales@pasternack.com)



## SMA Female Connector Solder Attachment 4 Hole Panel For PE-SR402AL, PE-SR402FL, RG402, .340 inch Hole Spacing

### TECHNICAL DATA SHEET

PE4121

#### SMA Female Connector Solder Attachment 4 Hole Panel For PE-SR402AL, PE-SR402FL, RG402, .340 inch Hole Spacing

##### Configuration

Connector	SMA Female
Connector Specification	MIL-STD-348, MIL-39012
Connector Interface Type	PE-SR402AL, PE-SR402FL, RG402
Cable Attachment Method (Shield/Contact)	Solder/Solder
Body Style	Straight
Mount Method	4 Hole Panel

##### Electrical Specifications

Frequency Range, GHz	DC to 18
Impedance, Ohms	50
Maximum VSWR	1.25:1

##### Mechanical Specifications

###### Size

Length, in [mm]	0.56 [14.22]
Width/Dia., in [mm]	0.5 [13]
Weight, lbs [g]	0.006 [2.72]

###### Connector

Type	SMA Female
Contact Material and Plating	Beryllium Copper, Gold
Contact Plating Specification	MIL-G-45204
Body Material and Plating	Stainless Steel, Gold
Body Plating Specification	MIL-G-45204
Dielectric Type	Teflon

##### Compliance Certifications (visit [www.Pasternack.com](http://www.Pasternack.com) for current document)

RoHS Compliant	Yes
----------------	-----

##### Plotted and Other Data

Notes: Values at 25 °C, sea level

URL: <http://www.pasternack.com/sma-female-standard-pe-sr402al-pe-sr402fl-rg402-connector-pe4121-p.aspx>

SMA Female Connector Solder Attachment 4 Hole Panel For PE-SR402AL, PE-SR402FL, RG402, .340 inch Hole Spacing from Pasternack Enterprises has same day shipment for domestic and International orders. We maintain 99% availability of the industry's broadest selection of RF, microwave and fiber optic products.

The information contained in this document is accurate to the best of our knowledge and representative of the part described herein. It may be necessary to make modifications to the part and/or the documentation of the part, in order to implement improvements. Pasternack reserves the right to make such changes as required. Unless otherwise stated, all specifications are nominal.

# PE4121 CAD Drawing

SMA Female Connector Solder Attachment 4 Hole Panel For PE-SR402AL, PE-SR402FL, RG402, .340 inch Hole Spacing

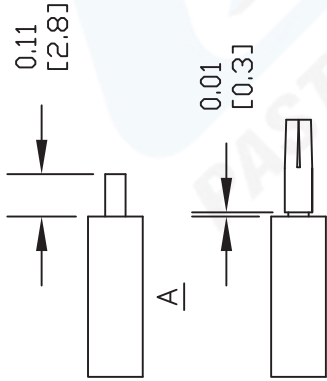
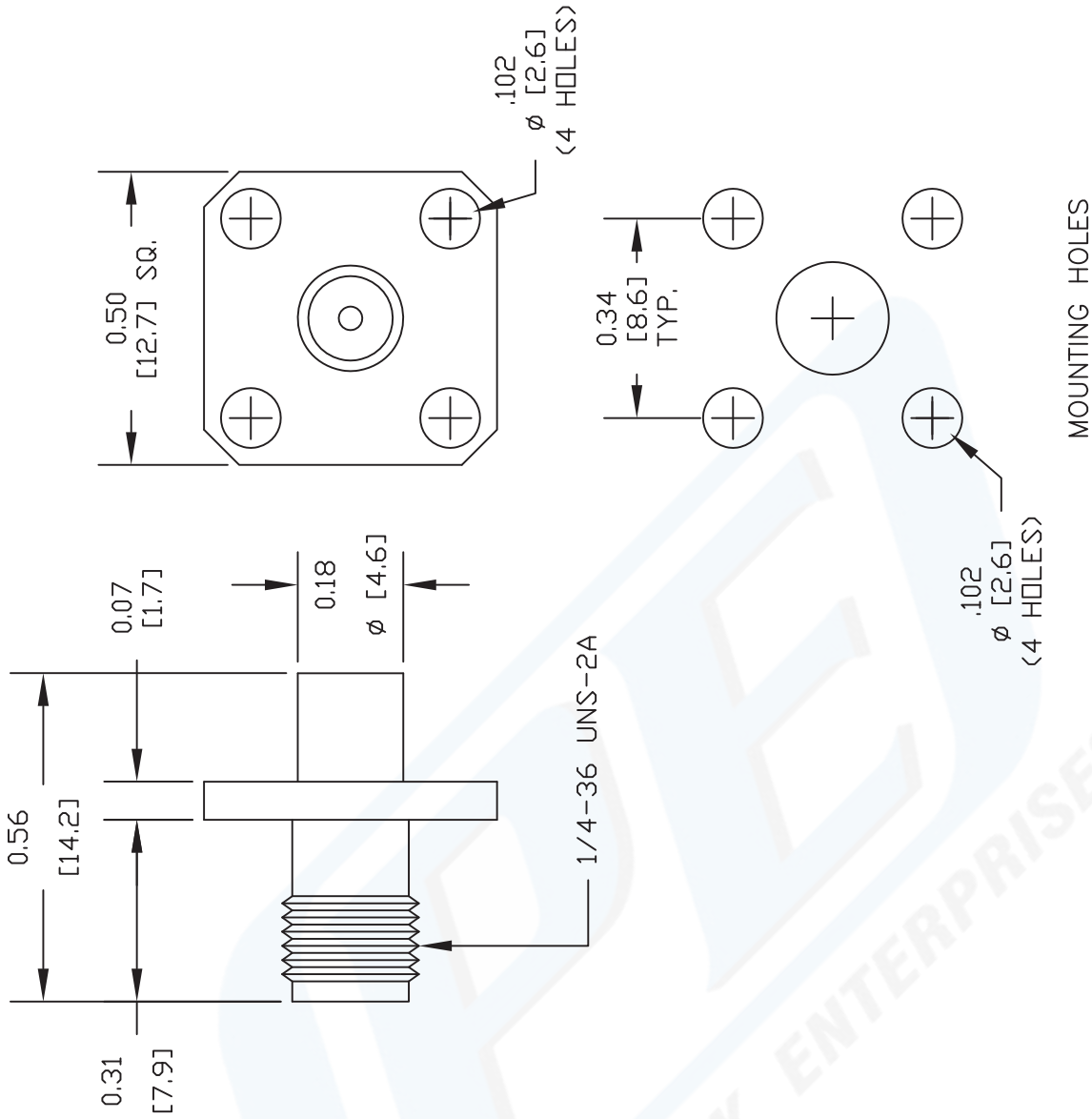

## STRIPPING DIMENSIONS

## ASSEMBLY PROCEDURES

1. STRIP CABLE AS SHOWN IN (A). DO NOT NICK CENTER CONDUCTOR.
2. SHIM CONTACT AS SHOWN IN (B) & SOLDER CONTACT TO CENTER CONDUCTOR.
3. INSERT CABLE INTO BODY UNTIL OUTER CONDUCTOR BOTTOMS OUT. SOLDER OUTER CONDUCTOR TO BODY.

DWG TITLE

**PE4121**

- NOTES:
1. UNLESS OTHERWISE SPECIFIED ALL DIMENSIONS ARE NOMINAL.
  2. ALL SPECIFICATIONS ARE SUBJECT TO CHANGE WITHOUT NOTICE AT ANY TIME.
  3. DIMENSIONS ARE IN INCHES [mm].
  4. FITS MIL-C-17 AND EQUIVALENT CABLES.

REV. A

FSCM NO. 53919

CAD FILE 083111

SCALE N/A

SIZE A

2231

**PE PASTERNAK®**  
 Pasternack Enterprises, Inc.  
 P.O. Box 16759 | Irvine | CA | 92623  
**Phone:** (949) 261-1920 | **Fax:** (949) 261-7451  
**Website:** www.pasternack.com | **E-Mail:** sales@pasternack.com



## Formable 141 Semirigid Coax Cable with Tinned Braid Outer Conductor and Black FEP Jacket

### RF Cables Technical Data Sheet

PE-SR402FLJ

#### Configuration

- Formable Cable
- 1 Shield(s)

#### Features

- Dimensionally the same as standard solid outer conductor semi-rigid coax
- Standard semi-rigid connectors can be used
- Cable is hand formable and does not require special tools to bend
- Connectors are easily soldered to Tin soaked outer conductor
- Cable can be formed more than once without damage to outer conductor
- High RF Shielding >100 dB

#### Description

Formable semi-rigid coax is a hand formable version of standard semi-rigid that does not require complicated and costly pre-formed cable assemblies. Because the dimensions and electrical characteristics are so closely matched to semi-rigid coax, standard semi-rigid connectors can be used. The tin soaked copper braid outer shield provides excellent RF shielding. FEP Jacket reduces the chance of shorting exposed contacts or circuit conductors.

#### Electrical Specifications

Description	Minimum	Typical	Maximum	Units
Frequency Range	DC		34	GHz
Impedance		50		Ohms
Velocity of Propagation		70		%
Time Delay		1.43 [4.69]		ns/ft [ns/m]
Shielding Effectiveness	100			dB
Operating Voltage (AC)			1,900	Vrms
Dielectric Withstanding Voltage (AC)			3,000	Vrms
Inner Conductor DC Resistance			8.23	Ohms/1000ft
Nominal Capacitance		29 [95.14]		pF/ft [pF/m]
Insulation Resistance	1,524			MOhms/1000ft

Click the following link (or enter part number in "SEARCH" on website) to obtain additional part information including price, inventory and certifications: [Formable 141 Semi-rigid Coax Cable with Tinned Copper Braid Outer Conductor and Black FEP Jacket PE-SR402FLJ](#)



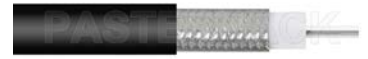

## Formable 141 Semirigid Coax Cable with Tinned Braid Outer Conductor and Black FEP Jacket

### RF Cables Technical Data Sheet

PE-SR402FLJ

#### Performance by Frequency Band

Description	F1	F2	F3	F4	F5	Units
Frequency	0.5	1	5	10	20	GHz
Attenuation, Typ	8.23	12.5	32	48.158	73.152	dB/100ft
	27	41.01	104.99	158	240	dB/100m
Input Power (CW), Max	436.5	303.4	126.7	85.5	56.6	Watts

#### Mechanical Specifications

Diameter	0.161 in [4.09 mm]
Weight	0.032 lbs/ft [0.05 Kg/m]
Min. Bend Radius (Installation)	0.315 in [8 mm]
Min. Bend Radius (Repeated)	1.575 in [40.01 mm]

#### Construction Specifications

Description	Material and Plating	Diameter
Inner Conductor	Copper Clad Steel, Silver, 1 Strands	0.036 in [0.91 mm]
Conductor Type	Solid	
Dielectric	PTFE	0.117 in [2.97 mm]
First Shield	Tinned Copper Braid	
Jacket	FEP, Black	0.161 in [4.09 mm]

#### Environmental Specifications

<b>Temperature</b>	
Operating Range	-65 to +150 deg C
Storage Range	10 to +35 deg C

Click the following link (or enter part number in "SEARCH" on website) to obtain additional part information including price, inventory and certifications: [Formable 141 Semi-rigid Coax Cable with Tinned Copper Braid Outer Conductor and Black FEP Jacket PE-SR402FLJ](#)



## Formable 141 Semirigid Coax Cable with Tinned Braid Outer Conductor and Black FEP Jacket

### RF Cables Technical Data Sheet

PE-SR402FLJ

**Compliance Certifications** (see [product page](#) for current document)

#### Plotted and Other Data

Notes:

Formable 141 Semirigid Coax Cable with Tinned Braid Outer Conductor and Black FEP Jacket from Pasternack Enterprises has same day shipment for domestic and International orders. Our RF, microwave and millimeter wave products maintain a 99.4% availability and are part of the broadest selection in the industry.

Click the following link (or enter part number in "SEARCH" on website) to obtain additional part information including price, inventory and certifications: [Formable 141 Semi-rigid Coax Cable with Tinned Copper Braid Outer Conductor and Black FEP Jacket PE-SR402FLJ](#)

URL: <https://www.pasternack.com/50-ohm-formable-141-semirigid-tinned-braid-outer-conductor-fep-jacket-black-pe-sr402flj-p.aspx>

The information contained in this document is accurate to the best of our knowledge and representative of the part described herein. It may be necessary to make modifications to the part and/or the documentation of the part, in order to implement improvements. Pasternack reserves the right to make such changes as required. Unless otherwise stated, all specifications are nominal. Pasternack does not make any representation or warranty regarding the suitability of the part described herein for any particular purpose, and Pasternack does not assume any liability arising out of the use of any part or documentation.



# PE-SR402FLJ CAD Drawing

Formable 141 Semirigid Coax Cable with Tinned Braid  
Outer Conductor and Black FEP Jacket

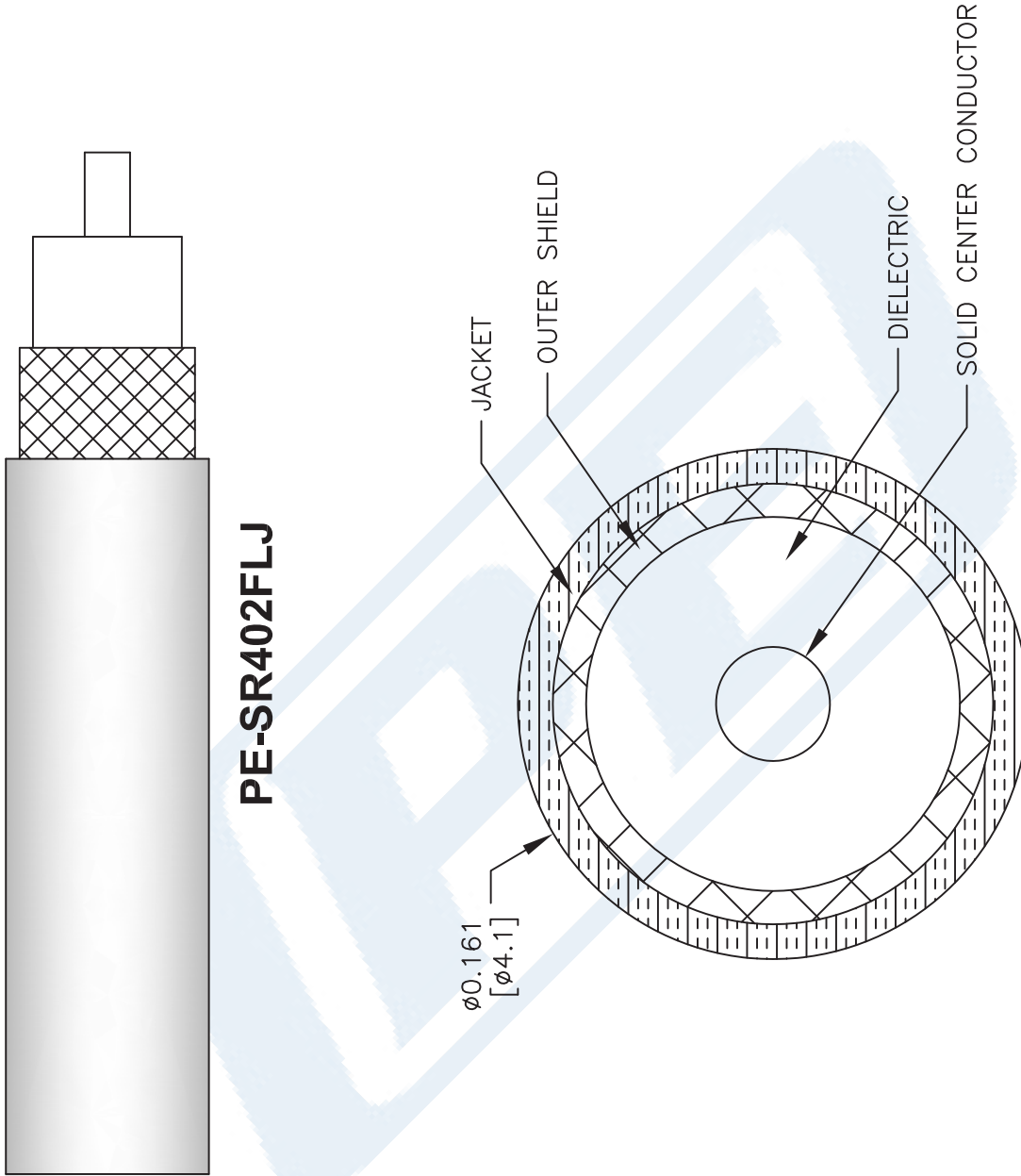

NOTES:  
 1. UNLESS OTHERWISE SPECIFIED ALL DIMENSIONS ARE NOMINAL.  
 2. ALL SPECIFICATIONS ARE SUBJECT TO CHANGE WITHOUT NOTICE AT ANY TIME.  
 3. DIMENSIONS ARE IN INCHES [mm].

DWG TITLE  
**PE-SR402FLJ**

CAD FILE 111716 SCALE N/A SIZE A 41742

FSCM NO. 53919

**PE PASTERNAK**  
 THE ENGINEER'S RF SOURCE  
 Pasternack Enterprises, Inc.  
 P.O. Box 16759 | Irvine | CA | 92623  
 Phone: (949) 261-1920 | Fax: (949) 261-7451  
 Website: www.pasternack.com | E-Mail: sales@pasternack.com