

NOTICE OF PROPRIETARY RIGHTS THIS DOCUMENT CONTAINS CONFIDENTIAL TECHNICAL DATA, INCLUDING TRADE SECRETS, PROPRIETARY TO TIMES MICROWAVE SYSTEMS. DISCLOSURE OF THIS DATA IS EXPRESSLY CONDITIONED UPON YOUR ASSENT THAT ITS USE IS LIMITED TO USE WITHIN YOUR COMPANY ONLY. ANY OTHER USE IS STRICTLY PROHIBITED WITHOUT THE PRIOR WRITTEN CONSENT OF TIMES MICROWAVE SYSTEMS.

SYM	REVISION DESCRIPTION	DFTM	DATE	APPD	DATE
A	RELEASED FOR PRODUCTION	D. J. H.	3/15/11	J. D. B.	8/16/11

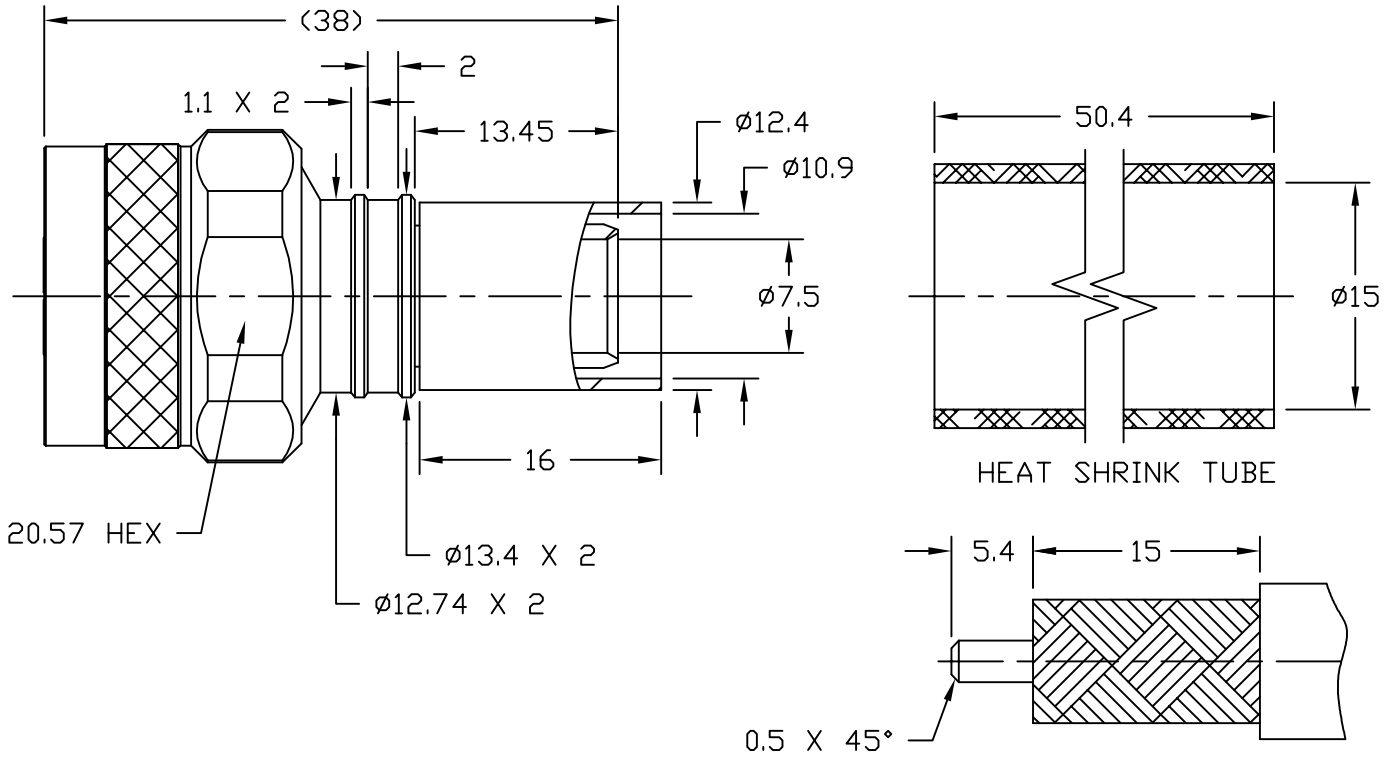

Reference standard IEC60169-16

I. Electric Performance

Impedance(Ω): 50

Frequency Range: DC-6GHz

VSWR: ≤ 1.25

Insert Loss: (dB) ≤ 0.1

Insulation resistance (M Ω) >5000

Work voltage (V) 1500

Conductor resistance (m Ω)
outer conductor <0.2
inner conductor <0.8

II. Mechanical Performance

Nut torque 25N.m

(Nut) Whorl pull 1000N

Tensile force (cable-connect) 400N

Torsion (cable-connect) 2N.m

III. Material and plating:

Component	Material	Plating
inner conductor	Brass	Au50 micro inches over nickel 100 over copper
outer conductor	Brass	copper tin-zinc 100-150 micro inches
tube	Copper	copper tin-zinc 100-150 micro inches
nut	Brass	copper tin-zinc 100-150 micro inches
gasket	Silicone rubber	
insulator	PTFE	

IV. Environment

Temp. range -55°C~+155°C

Weather standard IEC 60068 55 / 155/ 56

Thermal shock US MIL-STD 202, Meth.107, Cond.B

Vibration US MIL-STD 202, Meth.204, Cond.B

Shock US MIL-STD 202, Meth.213, Cond.I

V. Assembly: inner conductor soldered and outer conductor crimped.

MATERIAL:	UNLESS OTHERWISE SPECIFIED	DFTM. D. J. H.	TIMES MICROWAVE SYSTEMS
	ALL DIMENSIONS ARE IN mm MACHINED SURFACES FINISH N/A RMS MAX. REMOVE ALL BURRS N/A MAX. BREAK MACHINE CORNERS N/A MAX. FILLET R. TOLERANCES ON DECIMALS . XX \pm N/A . XXX \pm N/A ANGLES \pm 1° FRACTIONS \pm N/A	DATE 3/15/11	
USED ON: 0		CHKD. J. D. B.	TC-400-NMH-X "N" MALE FOR LMR-400 CABLE SOLDER/CRIMP/NO BRAID TRIM
		DATE 8/16/11	
SCALE: N/A	DWG. SIZE A	APPD. J. D. B.	SHEET 1 of 1 SD3190-2626 REV A
DO NOT SCALE DRAWING	CODE IDENT 68999	DATE 8/16/11	



N Male Right Angle Connector Crimp/Solder Attachment for PE-C400, PE-B400, PE-B405, LMR-400, LMR-400-DB, LMR-400-UF, 0.400 inch

RF Connectors Technical Data Sheet

PE44526

Configuration

- N Male Connector
- MIL-STD-348A
- 50 Ohms
- Right Angle Body Geometry
- PE-C400, PE-B400, PE-B405, LMR-400, LMR-400-DB, LMR-400-UF, 0.400 inch Interface Type
- Crimp/Solder Attachment

Features

- Max. Operating Frequency 11 GHz
- Good VSWR of 1.5:1
- Gold Plated Brass Contact
- 30 µin minimum contact plating

Applications

- General Purpose Test
- Custom Cable Assemblies

Description

Pasternack's PE44526 type N male right angle connector with crimp/solder attachment for PE-C400, PE-B400, PE-B405, LMR-400, LMR-400-DB, LMR-400-UF and 0.400 inch is part of our full line of RF components available for same-day shipping. Our type N male connector operates up to a maximum frequency of 11 GHz and offers good VSWR of 1.5:1. Its right angle body geometry allows for easier connections in tight spaces.

Our type N male right angle connector PE44526 datasheet specifications and drawing with dimensions are shown below in this PDF. Pasternack's broad catalog of RF, microwave and millimeter wave connectors allows designers to configure and customize their signal connections however they like. Whether the need is to provide an I/O for a board design, or simply create a custom cable assembly configuration, Pasternack has the right connector for the job. Pasternack can also expertly build your custom cable assemblies for you and ship same-day.

Electrical Specifications

Description	Minimum	Typical	Maximum	Units
Frequency Range	DC		11	GHz
VSWR			1.5:1	
Operating Voltage (AC)			1,500	Vrms
Dielectric Withstanding Voltage (AC)			2,500	Vrms
Inner Conductor DC Resistance			1	mOhms
Outer Conductor DC Resistance			1	mOhms
Insulation Resistance	5,000			MOhms
RF Leakage	90			dB

Click the following link (or enter part number in "SEARCH" on website) to obtain additional part information including price, inventory and certifications: [N Male Right Angle Connector Crimp/Solder Attachment for PE-C400, PE-B400, PE-B405, LMR-400, LMR-400-DB, LMR-400-UF, 0.400 inch PE44526](#)



N Male Right Angle Connector Crimp/Solder Attachment for PE-C400, PE-B400, PE-B405, LMR-400, LMR-400-DB, LMR-400-UF, 0.400 inch

RF Connectors Technical Data Sheet

PE44526

Performance by Frequency

Description	F1	F2	F3	F4	F5	Units
Frequency Range	DC to 10					GHz
Insertion Loss, Max	0.15					dB

Mechanical Specifications

Size

Length	1.31 in [33.27 mm]
Width/Dia.	0.83 in [21.08 mm]
Height	1.31 in [33.27 mm]
Weight	0.109 lbs [49.44 g]
Mating Cycles	500 Cycles

Material Specifications

Description	Material	Plating
Contact	Brass	Gold 30 µin minimum
Insulation	PTFE	
Body	Brass	Tri-Metal
Coupling Nut	Brass	Tri-Metal

Environmental Specifications

Temperature

Operating Range	-65 to +165 deg C
Vibration	MIL-STD-202, Method 204, Condition B
Temperature Cycle	MIL-STD-202, Method 107, Condition B
Salt Spray	MIL-STD-202, Method 101, Condition B

Click the following link (or enter part number in "SEARCH" on website) to obtain additional part information including price, inventory and certifications: [N Male Right Angle Connector Crimp/Solder Attachment for PE-C400, PE-B400, PE-B405, LMR-400, LMR-400-DB, LMR-400-UF, 0.400 inch PE44526](#)



N Male Right Angle Connector Crimp/Solder Attachment for PE-C400, PE-B400, PE-B405, LMR-400, LMR-400-DB, LMR-400-UF, 0.400 inch

RF Connectors Technical Data Sheet

PE44526

Compliance Certifications (see [product page](#) for current document)

Plotted and Other Data

Notes:

N Male Right Angle Connector Crimp/Solder Attachment for PE-C400, PE-B400, PE-B405, LMR-400, LMR-400-DB, LMR-400-UF, 0.400 inch from Pasternack Enterprises has same day shipment for domestic and International orders. Our RF, microwave and millimeter wave products maintain a 99% availability and are part of the broadest selection in the industry.

Click the following link (or enter part number in "SEARCH" on website) to obtain additional part information including price, inventory and certifications: [N Male Right Angle Connector Crimp/Solder Attachment for PE-C400, PE-B400, PE-B405, LMR-400, LMR-400-DB, LMR-400-UF, 0.400 inch PE44526](#)

URL: <https://www.pasternack.com/n-male-standard-pe-c400-0.400-connector-pe44526-p.aspx>

The information contained in this document is accurate to the best of our knowledge and representative of the part described herein. It may be necessary to make modifications to the part and/or the documentation of the part, in order to implement improvements. Pasternack reserves the right to make such changes as required. Unless otherwise stated, all specifications are nominal. Pasternack does not make any representation or warranty regarding the suitability of the part described herein for any particular purpose, and Pasternack does not assume any liability arising out of the use of any part or documentation.

PE44526 CAD Drawing

N Male Right Angle Connector Crimp/Solder Attachment for PE-C400, PE-B400, PE-B405, LMR-400, LMR-400-DB, LMR-400-UF, 0.400 inch

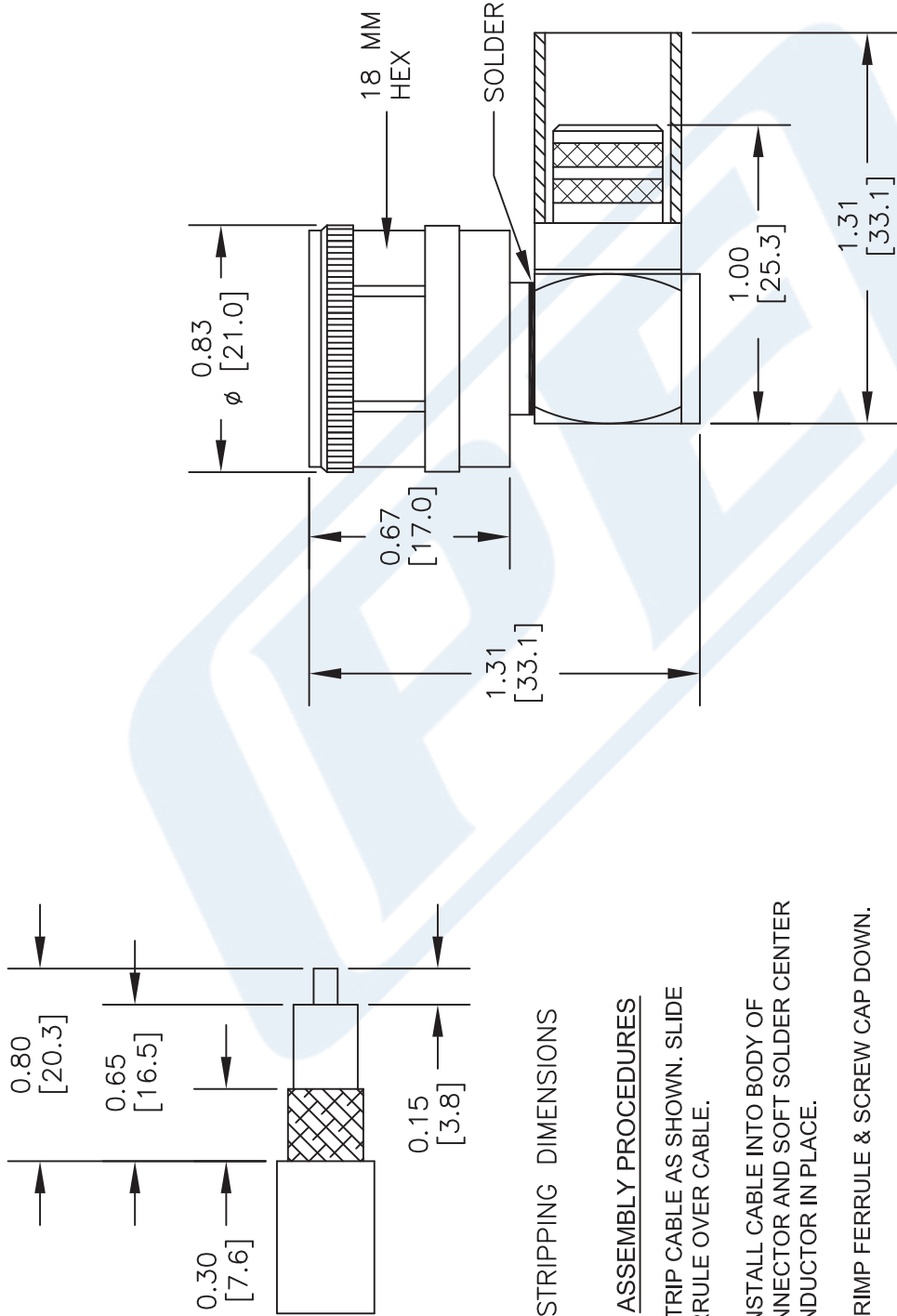

DWG TITLE

PE44526

FSCM NO. 53919

NOTES:
 1. UNLESS OTHERWISE SPECIFIED ALL DIMENSIONS ARE NOMINAL.
 2. ALL SPECIFICATIONS ARE SUBJECT TO CHANGE WITHOUT NOTICE AT ANY TIME.
 3. DIMENSIONS ARE IN INCHES [mm].

CAD FILE 040416

SCALE N/A

SIZE A

3045

PE PASTERNAK
 THE ENGINEER'S RF SOURCE

Pasternack Enterprises, Inc.
 P.O. Box 16759 | Irvine | CA | 92623
 Phone: (949) 261-1920 | Fax: (949) 261-7451
 Website: www.pasternack.com | E-Mail: sales@pasternack.com



Low Loss Flexible RG8 Type Coax Cable Double Shielded with Black PE Jacket

RF Cables Technical Data Sheet

PE-C400

Configuration

- Low Loss Flexible Cable
- 2 Shield(s)

Electrical Specifications

Description	Minimum	Typical	Maximum	Units
Frequency Range	DC		5.8	GHz
Impedance		50		Ohms
Velocity of Propagation		85		%
Shielding Effectiveness	90			dB
Inner Conductor DC Resistance			1.39	Ohms/1000ft
Outer Conductor DC Resistance			1.85	Ohms/1000ft
Nominal Capacitance		23.9 [78.41]		pF/ft [pF/m]
Nominal Inductance		0.059 [0.19]		uH/ft [uH/m]

Performance by Frequency Band

Description	F1	F2	F3	F4	F5	Units
Frequency	150	220	450	750	900	MHz
Attenuation, Typ	1.5	1.9	2.7	3.55	3.9	dB/100ft
	4.92	6.23	8.86	11.65	12.8	dB/100m
Input Power (CW), Max	1,280	1,050	720	560	500	Watts

Description	F6	F7	F8	F9	F10	Units
Frequency	1.5	1.8	2	2.5	5.8	GHz
Attenuation, Typ	5.1	5.7	6	6.8	10.8	dB/100ft
	16.73	18.7	19.69	22.31	35.43	dB/100m
Input Power (CW), Max	380	340	330	290	180	Watts

Mechanical Specifications

Diameter	0.405 in [10.29 mm]
Weight	0.064 lbs/ft [0.1 Kg/m]

Click the following link (or enter part number in "SEARCH" on website) to obtain additional part information including price, inventory and certifications: [Low Loss Flexible RG8 Type Coax Cable Double Shielded with Black PE Jacket PE-C400](#)



Low Loss Flexible RG8 Type Coax Cable Double Shielded with Black PE Jacket

RF Cables Technical Data Sheet

PE-C400

Min. Bend Radius (Repeated) 4 in [101.6 mm]

Construction Specifications

Description	Material and Plating	Diameter
Inner Conductor	Copper, 1 Strands	0.108 in [2.74 mm]
Conductor Type	Solid	
Dielectric	PE (F)	0.285 in [7.24 mm]
First Shield	Aluminum Tape	
Second Shield	Tinned Copper Braid	0.32 in [8.13 mm]
Jacket	PE, Black	0.405 in [10.29 mm]

Environmental Specifications

Temperature

Operating Range	-40 to +85 deg C
Installation Range	-70 to +85 deg C
Storage Range	-40 to +85 deg C

Compliance Certifications (see [product page](#) for current document)

Plotted and Other Data

Notes:

Low Loss Flexible RG8 Type Coax Cable Double Shielded with Black PE Jacket from Pasternack Enterprises has same day shipment for domestic and International orders. Our RF, microwave and millimeter wave products maintain a 99.4% availability and are part of the broadest selection in the industry.

Click the following link (or enter part number in "SEARCH" on website) to obtain additional part information including price, inventory and certifications: [Low Loss Flexible RG8 Type Coax Cable Double Shielded with Black PE Jacket PE-C400](#)

URL: <https://www.pasternack.com/flexible-0.405-50-ohm-coax-cable-pe-jacket-pe-c400-p.aspx>

The information contained in this document is accurate to the best of our knowledge and representative of the part described herein. It may be necessary to make modifications to the part and/or the documentation of the part, in order to implement improvements. Pasternack reserves the right to make such changes as required. Unless otherwise stated, all specifications are nominal. Pasternack does not make any representation or warranty regarding the suitability of the part described herein for any particular purpose, and Pasternack does not assume any liability arising out of the use of any part or documentation.

PE-C400 CAD Drawing

Low Loss Flexible RG8 Type Coax Cable Double Shielded with Black PE Jacket

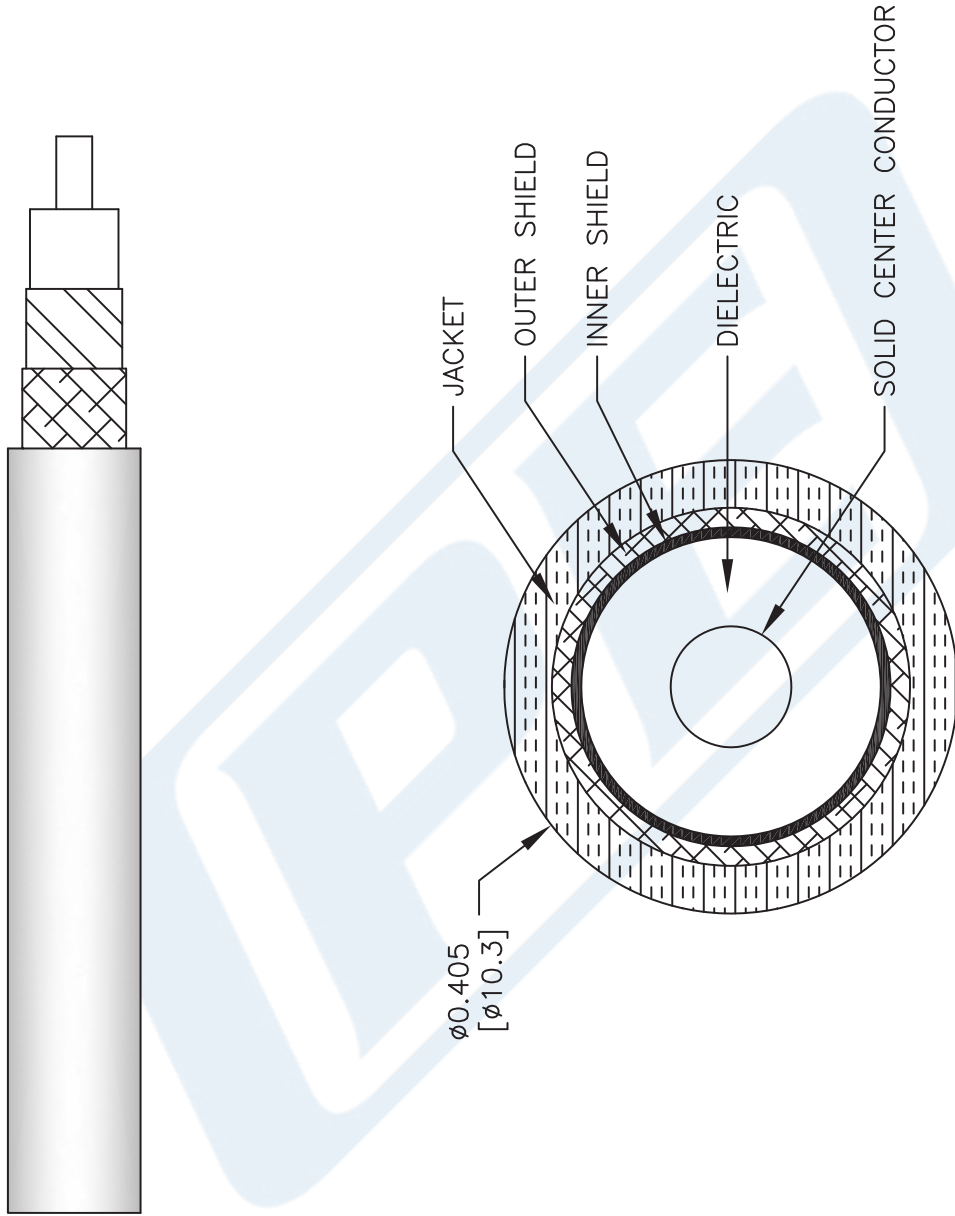

NOTES:
 1. UNLESS OTHERWISE SPECIFIED ALL DIMENSIONS ARE NOMINAL.
 2. ALL SPECIFICATIONS ARE SUBJECT TO CHANGE WITHOUT NOTICE AT ANY TIME.
 3. DIMENSIONS ARE IN INCHES [mm].

DWG TITLE
PE-C400

FSCM NO. 53919

SCALE N/A

SIZE A

CAD FILE 111716

41742

PE PASTERNAK
 THE ENGINEER'S RF SOURCE
 Pasternack Enterprises, Inc.
 P.O. Box 16759 | Irvine | CA | 92623
 Phone: (949) 261-1920 | Fax: (949) 261-7451
 Website: www.pasternack.com | E-Mail: sales@pasternack.com