



Mini SMP Female Connector Solder Attachment for PE-SR405AL, PE-SR405FL, PE-SR405FLJ, PE-SR405TN, RG405

RF Connectors  
Technical Data Sheet

PE44974

**Configuration**

- Mini SMP Female Connector
- 50 Ohms
- Straight Body Geometry
- Connector Interface Types: PE-SR405AL, PE-SR-405FL, PE-SR405FLJ, PE-SR405TN, RG405

**Features**

- Max. Operating Frequency 26.5 GHz
- Excellent VSWR of 1.15:1
- Gold Plated Beryllium Copper Contact
- Contact plating according to MIL-G-45204
- Blind Mate Connector

**Applications**

- General Purpose Test
- Custom Cable Assemblies

**Description**

Pasternack's PE44974 Mini SMP female connector with solder attachment for PE-SR405AL, PE-SR405FL, PE-SR405FLJ, PE-SR405TN and RG405 is part of our full line of RF components available for same-day shipping. Our Mini SMP female connector operates up to a maximum frequency of 26.5 GHz and offers excellent VSWR of 1.15:1. The Pasternack blind mate connector is ideal for applications where direct visual or tactile access to the connection point is not possible, for example, when two circuit boards need to be mated.

Our Mini SMP female connector PE44974 datasheet specifications and drawing with dimensions are shown below in this PDF. Pasternack's broad catalog of RF, microwave and millimeter wave connectors allows designers to configure and customize their signal connections however they like. Whether the need is to provide an I/O for a board design, or simply create a custom cable assembly configuration, Pasternack has the right connector for the job. Pasternack can also expertly build your custom cable assemblies for you and ship same-day.

**Electrical Specifications**

Description	Minimum	Typical	Maximum	Units
Frequency Range	DC		26.5	GHz
VSWR			1.15:1	

**Mechanical Specifications**

<b>Size</b>	
Length	0.29 in [7.37 mm]
Width/Dia.	0.125 in [3.18 mm]
Weight	0.005 lbs [2.27 g]

Click the following link (or enter part number in "SEARCH" on website) to obtain additional part information including price, inventory and certifications: [Mini SMP Female Connector Solder Attachment for PE-SR405AL, PE-SR405FL, PE-SR-405FLJ, PE-SR405TN, RG405 PE44974](#)



Mini SMP Female Connector Solder Attachment for PE-SR405AL, PE-SR405FL, PE-SR405FLJ, PE-SR405TN, RG405

RF Connectors  
Technical Data Sheet

PE44974

**Material Specifications**

Description	Material	Plating
Contact	Beryllium Copper	Gold MIL-G-45204
Insulation	PTFE	
Body	Beryllium Copper	Gold MIL-G-45204

**Environmental Specifications**

**Temperature**

Operating Range -65 to +165 deg C

**Compliance Certifications** (see [product page](#) for current document)

**Plotted and Other Data**

Notes:

Mini SMP Female Connector Solder Attachment for PE-SR405AL, PE-SR405FL, PE-SR405FLJ, PE-SR405TN, RG405 from Pasternack Enterprises has same day shipment for domestic and International orders. Our RF, microwave and millimeter wave products maintain a 99.4% availability and are part of the broadest selection in the industry.

Click the following link (or enter part number in "SEARCH" on website) to obtain additional part information including price, inventory and certifications: [Mini SMP Female Connector Solder Attachment for PE-SR405AL, PE-SR405FL, PE-SR405FLJ, PE-SR405TN, RG405 PE44974](#)

URL: <https://www.pasternack.com/mini-smp-female-standard-rg405-pe-sr405fl-connector-pe44974-p.aspx>

The information contained in this document is accurate to the best of our knowledge and representative of the part described herein. It may be necessary to make modifications to the part and/or the documentation of the part, in order to implement improvements. Pasternack reserves the right to make such changes as required. Unless otherwise stated, all specifications are nominal. Pasternack does not make any representation or warranty regarding the suitability of the part described herein for any particular purpose, and Pasternack does not assume any liability arising out of the use of any part or documentation.

# PE44974 CAD Drawing

Mini SMP Female Connector Solder Attachment for PE-SR405AL,  
PE-SR405FL, PE-SR405FLJ, PE-SR405TN, RG405

REVISIONS			
REV.	DESCRIPTION	DATE	APPROVED
A	PCR PE44974 SC5431 20200916	09/30/20	SRAUTJUS

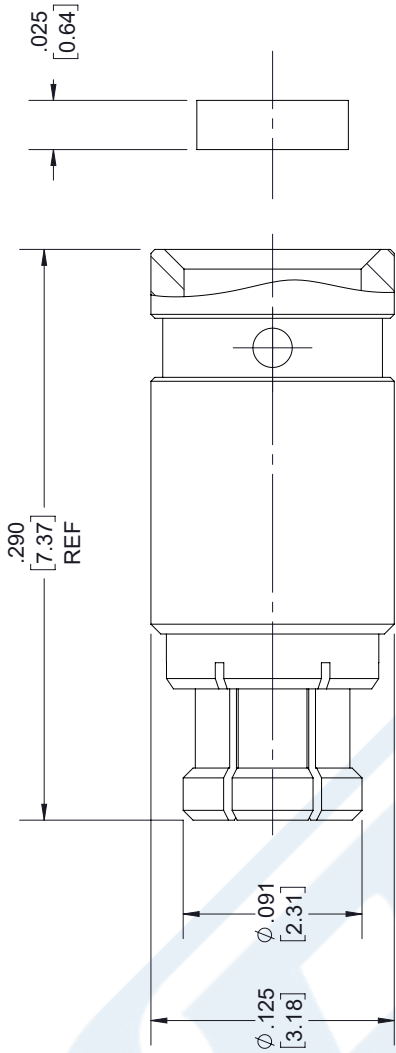

Mini SMP  
FEMALE

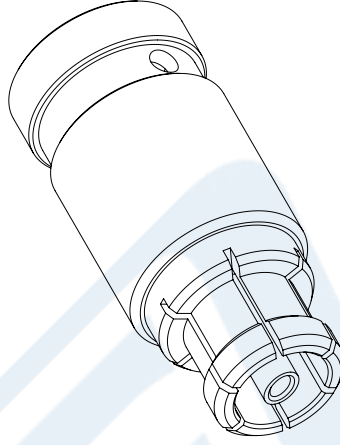

### ASSEMBLY PROCEDURES:

1. TRIM CABLE OUTER CONDUCTOR AND DIELECTRIC TO DIMENSION SHOWN, DO NOT NICK CENTER CONDUCTOR.
2. CLEAN CABLE OUTER CONDUCTOR USING FINE GRAIN SANDPAPER OR STEEL WOOL AS SHOWN.

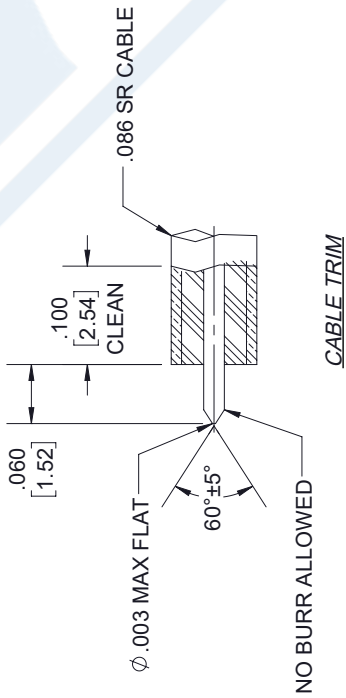

3. SLIDE DIELECTRIC BEAD ONTO CENTER CONDUCTOR UNTIL IT SEATS AGAINST CABLE.
4. FULLY INSTALL CABLE SUBASSEMBLY INTO BODY AND SOLDER IN PLACE. ENSURE THE CABLE JACKET IS AGAINST CABLE STOP PRIOR TO SOLDERING.

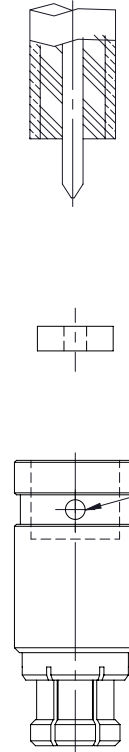

UNLESS OTHERWISE SPECIFIED LEADING DIMENSIONS ARE INCHES DIMENSIONS IN [ ] ARE MILLIMETERS	
.X = ±.2	[.08] FRACTIONS ± 1/32
.XX = ±.02	[.51] ANGLES ± 1°
.XXX = ±.005	[.13] TOLERANCES:
CABLE LENGTH (L) TOLERANCES:	
L ≤ 12 [305]	= +1 [25] / -0
12 [305] < L ≤ 60 [1524]	= +2 [51] / -0
60 [1524] < L ≤ 120 [3048]	= +4 [102] / -0
120 [3048] < L ≤ 300 [7620]	= +6 [152] / -0
300 [7620] < L	= +5%L / -0
ALL DIMENSIONS SHOWN ARE FOR REFERENCE ONLY.	



Pasternack Enterprises, Inc.  
P. O. Box 16759, Irvine, CA 92623.  
Phone: 1.949.261.1920 | 1.866.727.8376  
Fax: 1.949.261.7451  
Website: www.pasternack.com  
E-mail: sales@pasternack.com

THIRD-ANGLE PROJECTION	THE INFORMATION AND DESIGN ARE PROPERTY OF PASTERNAK CORPORATION ALL RIGHTS RESERVED.
SHEET 1	OF 1
SCALE	N/A
CAGE CODE	ITEM NO.
A 53919	SLI
DRAWN BY	PE44974
REV	A



## SMA Male Connector Solder Attachment for RG405, RG405 Tinned

### RF Connectors Technical Data Sheet

PE45481

#### Configuration

- SMA Male Connector
- 50 Ohms
- Straight Body Geometry
- RG405, RG405 Tinned Interface Type
- Solder Attachment

#### Features

- Max. Operating Frequency 26.5 GHz
- Excellent VSWR of 1.14:1
- Gold Plated Beryllium Copper Contact
- Contact plating according to ASTM-B488

#### Applications

- General Purpose Test
- Custom Cable Assemblies

#### Description

Pasternack's PE45481 SMA male connector with solder attachment for RG405 and RG405 Tinned is part of our full line of RF components available for same-day shipping. Our SMA male connector operates up to a maximum frequency of 26.5 GHz and offers excellent VSWR of 1.14:1.

Our SMA male connector PE45481 datasheet specifications and drawing with dimensions are shown below in this PDF. Pasternack's broad catalog of RF, microwave and millimeter wave connectors allows designers to configure and customize their signal connections however they like. Whether the need is to provide an I/O for a board design, or simply create a custom cable assembly configuration, Pasternack has the right connector for the job. Pasternack can also expertly build your custom cable assemblies for you and ship same-day.

#### Electrical Specifications

Description	Minimum	Typical	Maximum	Units
Frequency Range	DC		26.5	GHz
VSWR			1.14:1	
Dielectric Withstanding Voltage (AC)			1,000	Vrms
High Potential Voltage			670	Vrms
Corona Discharge			250	Vrms
Insulation Resistance	5,000			MOhms
RF Leakage	-90			dB

Click the following link (or enter part number in "SEARCH" on website) to obtain additional part information including price, inventory and certifications: [SMA Male Connector Solder Attachment for RG405, RG405 Tinned PE45481](#)



SMA Male Connector Solder Attachment  
for RG405, RG405 Tinned

RF Connectors  
Technical Data Sheet

PE45481

**Performance by Frequency**

Description	F1	F2	F3	F4	F5	Units
Frequency Range	DC to 18	18 to 16.5				GHz
VSWR, Max	1.11:1	1.14:1				

Electrical Specification Notes:  
Insertion Loss = 0.04\*SQRT(Fghz) dB

**Mechanical Specifications**

Mating Cycles 500 Cycles  
Mating Torque 7 to 10 in-lbs [0.79 to 1.13 Nm]

**Material Specifications**

Description	Material	Plating
Contact	Beryllium Copper	Gold ASTM-B488
Insulation	PTFE	
Body	Beryllium Copper	Gold ASTM-B488
Coupling Nut	Steel	
Gasket	Silicone Rubber	

**Environmental Specifications**

**Temperature**  
Operating Range -65 to +165 deg C  
**Shock** MIL-STD-202, Method 213, Condition I  
**Vibration** MIL-STD-202, Method 204, Condition D  
**Thermal Shock** MIL-STD-202, Method 107, Condition B

**Compliance Certifications** (see [product page](#) for current document)

**Plotted and Other Data**

Notes:

Click the following link (or enter part number in "SEARCH" on website) to obtain additional part information including price, inventory and certifications: [SMA Male Connector Solder Attachment for RG405, RG405 Tinned PE45481](#)



SMA Male Connector Solder Attachment  
for RG405, RG405 Tinned

RF Connectors  
Technical Data Sheet

PE45481

**Assembly Instruction**

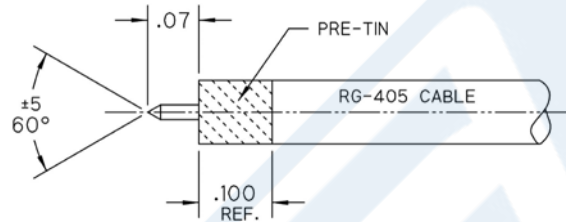

**STEP 1:**

- TRIM CABLE TO EXPOSE CENTER CONDUCTOR AS SHOWN.
- PRE-TIN CABLE OUTER JACKET OVER APPROX. LENGTH SHOWN.

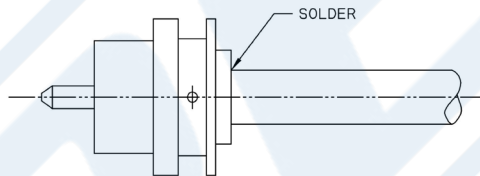

**STEP 2:**

- INSERT CABLE INTO CONNECTOR BODY UNTIL CENTER CONDUCTOR PLUGS IN AND CABLE FULLY SEATS IN CONNECTOR BORE.
- SOLDER CABLE TO BODY WHERE SHOWN.

**STEP 3:**

- INSTALL LOCK RING, GASKET, AND COUPLING NUT ONTO MAIN BODY USING APPROPRIATE SMA ASSEMBLY TOOLS.

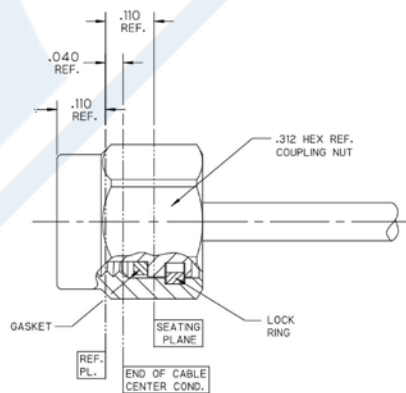

Click the following link (or enter part number in "SEARCH" on website) to obtain additional part information including price, inventory and certifications: [SMA Male Connector Solder Attachment for RG405, RG405 Tinned PE45481](#)



## SMA Male Connector Solder Attachment for RG405, RG405 Tinned

### RF Connectors Technical Data Sheet

PE45481

SMA Male Connector Solder Attachment for RG405, RG405 Tinned from Pasternack Enterprises has same day shipment for domestic and International orders. Our RF, microwave and millimeter wave products maintain a 99.4% availability and are part of the broadest selection in the industry.

Click the following link (or enter part number in "SEARCH" on website) to obtain additional part information including price, inventory and certifications: [SMA Male Connector Solder Attachment for RG405, RG405 Tinned PE45481](https://www.pasternack.com/sma-male-rg405-rg405-tinned-connector-pe45481-p.aspx)

URL: <https://www.pasternack.com/sma-male-rg405-rg405-tinned-connector-pe45481-p.aspx>

The information contained in this document is accurate to the best of our knowledge and representative of the part described herein. It may be necessary to make modifications to the part and/or the documentation of the part, in order to implement improvements. Pasternack reserves the right to make such changes as required. Unless otherwise stated, all specifications are nominal. Pasternack does not make any representation or warranty regarding the suitability of the part described herein for any particular purpose, and Pasternack does not assume any liability arising out of the use of any part or documentation.

# PE45481 CAD Drawing

SMA Male Connector Solder Attachment for RG405, RG405 Tinned

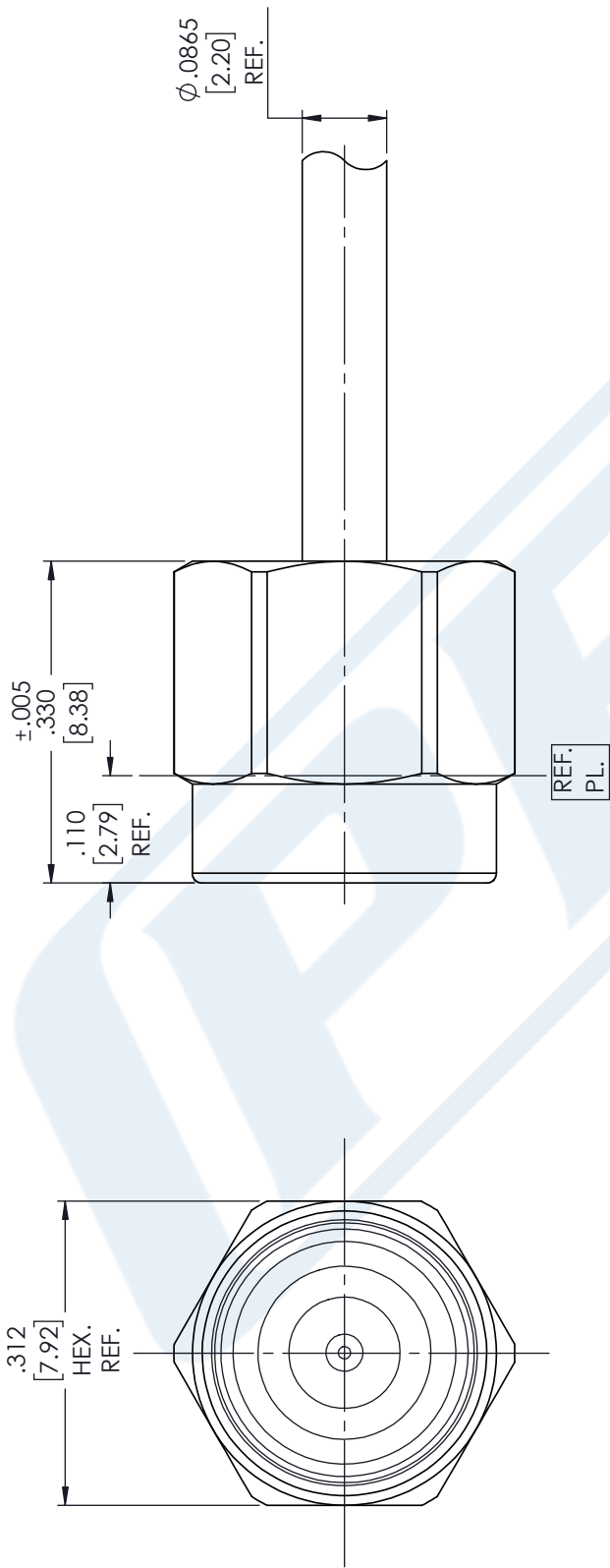

STANDARD TOLERANCES	
.X	±0.2
.XX	±0.01
.XXX	±0.005

\*STANDARD TOLERANCES APPLY ONLY TO DIMENSIONS IN INCHES NOTES: DISTANCE FROM END OF CABLE CENTER COND. TO REF. PL. IS .040



Pasternack Enterprises, Inc.  
 P.O. Box 16759 | Irvine | CA | 92623  
**Phone:** (949) 261-1920 | **Fax:** (949) 261-7451  
**Website:** www.pasternack.com | **E-Mail:** sales@pasternack.com

DWG TITLE  
 PE45481

**CAGE CODE 53919**

NOTES:  
 1. UNLESS OTHERWISE SPECIFIED ALL DIMENSIONS ARE NOMINAL.  
 2. ALL SPECIFICATIONS ARE SUBJECT TO CHANGE WITHOUT NOTICE AT ANY TIME  
 3. DIMENSIONS ARE IN INCHES [mm].

CAD FILE 07/26/18

SCALE N/A

SIZE A  
 CN2379





## Formable 086 Semirigid Coax Cable with Tinned Braid Outer Conductor and Black FEP Jacket

### RF Cables Technical Data Sheet

PE-SR405FLJ

#### Configuration

- Formable Cable
- 1 Shield(s)

#### Features

- Dimensionally the same as standard solid outer conductor semi-rigid coax
- Standard semi-rigid connectors can be used
- Cable is hand formable and does not require special tools to bend
- Connectors are easily soldered to Tin soaked outer conductor
- Cable can be formed more than once without damage to outer conductor
- High RF Shielding >100 dB

#### Description

Formable semi-rigid coax is a hand formable version of standard semi-rigid that does not require complicated and costly pre-formed cable assemblies. Because the dimensions and electrical characteristics are so closely matched to semi-rigid coax, standard semi-rigid connectors can be used. The tin soaked copper braid outer shield provides excellent RF shielding. FEP Jacket reduces the chance of shorting exposed contacts or circuit conductors.

#### Electrical Specifications

Description	Minimum	Typical	Maximum	Units
Frequency Range	DC		61	GHz
Impedance		50		Ohms
Velocity of Propagation		69.5		%
Time Delay		1.43 [4.69]		ns/ft [ns/m]
Shielding Effectiveness	100			dB
Operating Voltage (AC)			1,500	Vrms
Inner Conductor DC Resistance			65.7	Ohms/1000ft
Outer Conductor DC Resistance			10.2	Ohms/1000ft
Nominal Capacitance		29 [95.14]		pF/ft [pF/m]

#### Performance by Frequency Band

Description	F1	F2	F3	F4	F5	Units
Frequency	0.5	1	5	10	20	GHz
Attenuation, Typ	15	22.5	54.9	81.2	120	dB/100ft
	49.21	73.82	180.12	266.4	393.7	dB/100m
Input Power (CW), Max	173.5	121.5	52.2	35.8	24.3	Watts

Click the following link (or enter part number in "SEARCH" on website) to obtain additional part information including price, inventory and certifications: [Formable PE-SR405FLJ Coax Cable with Outer Conductor and Black FEP Jacket PE-SR-405FLJ](#)



## Formable 086 Semirigid Coax Cable with Tinned Braid Outer Conductor and Black FEP Jacket

### RF Cables Technical Data Sheet

PE-SR405FLJ

#### Mechanical Specifications

Diameter	0.105 in [2.67 mm]
Weight	0.015 lbs/ft [0.02 Kg/m]
Min. Bend Radius (Installation)	0.5 in [12.7 mm]
Min. Bend Radius (Repeated)	0.787 in [19.99 mm]

#### Construction Specifications

Description	Material and Plating	Diameter
Inner Conductor	Copper Clad Steel, Silver, 1 Strands	0.02 in [0.51 mm]
Conductor Type	Solid	
Dielectric	PTFE	0.062 in [1.57 mm]
Outer Conductor	Tinned Copper Composite Braid	0.085 in [2.16 mm]
Jacket	FEP, Black	0.105 in [2.67 mm]

#### Environmental Specifications

##### Temperature

Operating Range	-55 to +125 deg C
-----------------	-------------------

#### Compliance Certifications (see [product page](#) for current document)

#### Plotted and Other Data

Notes:

Formable 086 Semirigid Coax Cable with Tinned Braid Outer Conductor and Black FEP Jacket from Pasternack Enterprises has same day shipment for domestic and International orders. Our RF, microwave and millimeter wave products maintain a 99.4% availability and are part of the broadest selection in the industry.

Click the following link (or enter part number in "SEARCH" on website) to obtain additional part information including price, inventory and certifications: [Formable PE-SR405FLJ Coax Cable with Outer Conductor and Black FEP Jacket PE-SR405FLJ](#)

URL: <https://www.pasternack.com/50-ohm-formable-086-semirigid-tinned-braid-outer-conductor-fep-jacket-black-pe-sr405flj-p.aspx>

The information contained in this document is accurate to the best of our knowledge and representative of the part described herein. It may be necessary to make modifications to the part and/or the documentation of the part, in order to implement improvements. Pasternack reserves the right to make such changes as required. Unless otherwise stated, all specifications are nominal. Pasternack does not make any representation or warranty regarding the suitability of the part described herein for any particular purpose, and Pasternack does not assume any liability arising out of the use of any part or documentation.

# PE-SR405FLJ CAD Drawing

Formable 086 Semirigid Coax Cable with Tinned Braid  
Outer Conductor and Black FEP Jacket

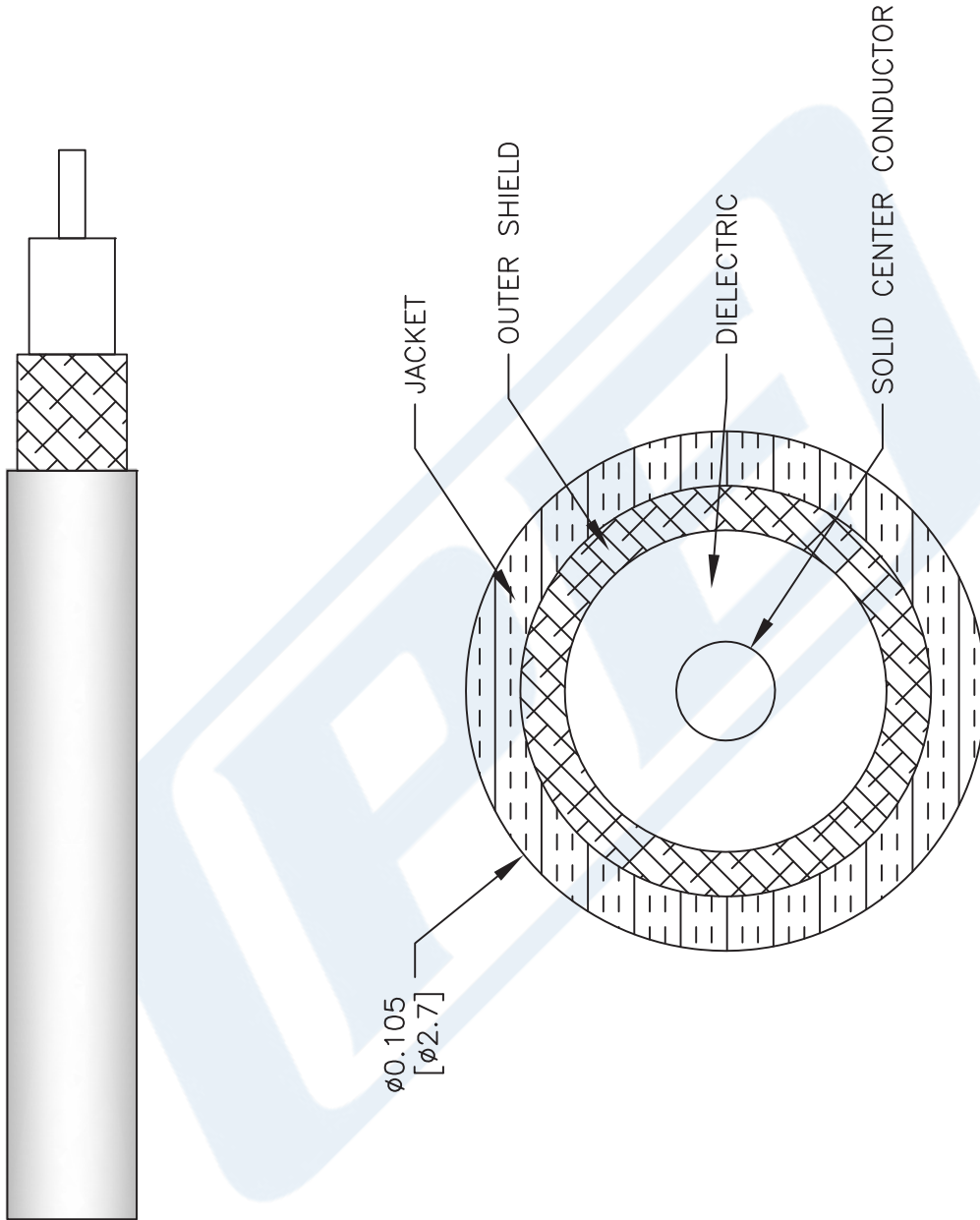

NOTES:  
1. UNLESS OTHERWISE SPECIFIED ALL DIMENSIONS ARE NOMINAL.  
2. ALL SPECIFICATIONS ARE SUBJECT TO CHANGE WITHOUT NOTICE AT ANY TIME.  
3. DIMENSIONS ARE IN INCHES [mm].

DWG TITLE  
**PE-SR405FLJ**

CAGE CODE 53919

CAD FILE 062817

SCALE N/A

SIZE A

2233

**(PE) PASTERNAK®**  
THE ENGINEER'S RF SOURCE  
Pasternack Enterprises, Inc.  
P.O. Box 16759 | Irvine | CA | 92623

Phone: (949) 261-1920 | Fax: (949) 261-7451

Website: www.pasternack.com | E-Mail: sales@pasternack.com