



WR-62 UBR140 Flange to N Female Waveguide to Coax Adapter Operating from 11.9 GHz to 18 GHz in Brass

Waveguide to Coax Adapters Technical Data Sheet

PEWCA1097

Features

- 11.9 to 18 GHz Frequency Range
- WR-62 Waveguide Interface
- UBR140 Flange
- N Female RF Interface
- Comprehensive waveguide offering also include E-Bends, H-Bends, Sections, Filters, Terminations, Couplers, and more.

Applications

- Test Benches
- Radar
- Satellite
- Microwave Radio Systems
- Military and Space
- Communication Systems

Description

The PEWCA1097 is a right angle waveguide to coaxial adapter operating at a frequency range of 11.9 GHz to 18 GHz. This adapter offers a WR-62 waveguide interface size coupled with a precision tolerance UBR140 flange. The PEWCA1097 is constructed of brass and painted gray to ensure durability. The coaxial connector offered by this adapter uses an N Female connector.

Configuration

Waveguide Size	WR-62
Flange	UBR140
RF Connector	N Female
Body Geometry	Right Angle

Electrical Specifications

Description	Minimum	Typical	Maximum	Units
Frequency Range	11.9		18	GHz
VSWR			1.25:1	
Insertion Loss			0.2	dB
Input Power (CW)			100	Watts

Mechanical Specifications

Size	
Length	1.25 in [31.75 mm]
Width	1.31 in [33.27 mm]
Height	1.31 in [33.27 mm]

RF Connector	
Connector Type	N Female

Waveguide Interface	
Waveguide Type	WR-62

Click the following link (or enter part number in "SEARCH" on website) to obtain additional part information including price, inventory and certifications: [WR-62 UBR140 Flange to N Female Waveguide to Coax Adapter Operating from 11.9 GHz to 18 GHz in Brass PEWCA1097](#)



WR-62 UBR140 Flange to N Female Waveguide to Coax Adapter Operating from 11.9 GHz to 18 GHz in Brass

Waveguide to Coax Adapters Technical Data Sheet

PEWCA1097

Flange Type UBR140
Body Material and Plating Brass

Environmental Specifications

Temperature

Operating Range -40 to +70 deg C

Compliance Certifications (see [product page](#) for current document)

Plotted and Other Data

Notes:

- Values at +25 °C, sea level unless stated otherwise

WR-62 UBR140 Flange to N Female Waveguide to Coax Adapter Operating from 11.9 GHz to 18 GHz in Brass from Pasternack Enterprises has same day shipment for domestic and International orders. Our RF, microwave and millimeter wave products maintain a 99.4% availability and are part of the broadest selection in the industry.

Click the following link (or enter part number in "SEARCH" on website) to obtain additional part information including price, inventory and certifications: [WR-62 UBR140 Flange to N Female Waveguide to Coax Adapter Operating from 11.9 GHz to 18 GHz in Brass PEWCA1097](#)

URL: <https://www.pasternack.com/wr62-ubr140-flange-to-type-n-female-waveguide-coax-adapter-18-ghz-pewca1097-p.aspx>

The information contained in this document is accurate to the best of our knowledge and representative of the part described herein. It may be necessary to make modifications to the part and/or the documentation of the part, in order to implement improvements. Pasternack reserves the right to make such changes as required. Unless otherwise stated, all specifications are nominal. Pasternack does not make any representation or warranty regarding the suitability of the part described herein for any particular purpose, and Pasternack does not assume any liability arising out of the use of any part or documentation.

PEWCA1097 CAD Drawing

WR-62 UBR140 Flange to N Female Waveguide to Coax Adapter Operating from 11.9 GHz to 18 GHz in Brass

REVISIONS			
REV.	DESCRIPTION	DATE	APPROVED
A	INITIAL RELEASE	05/08/2020	SPONG

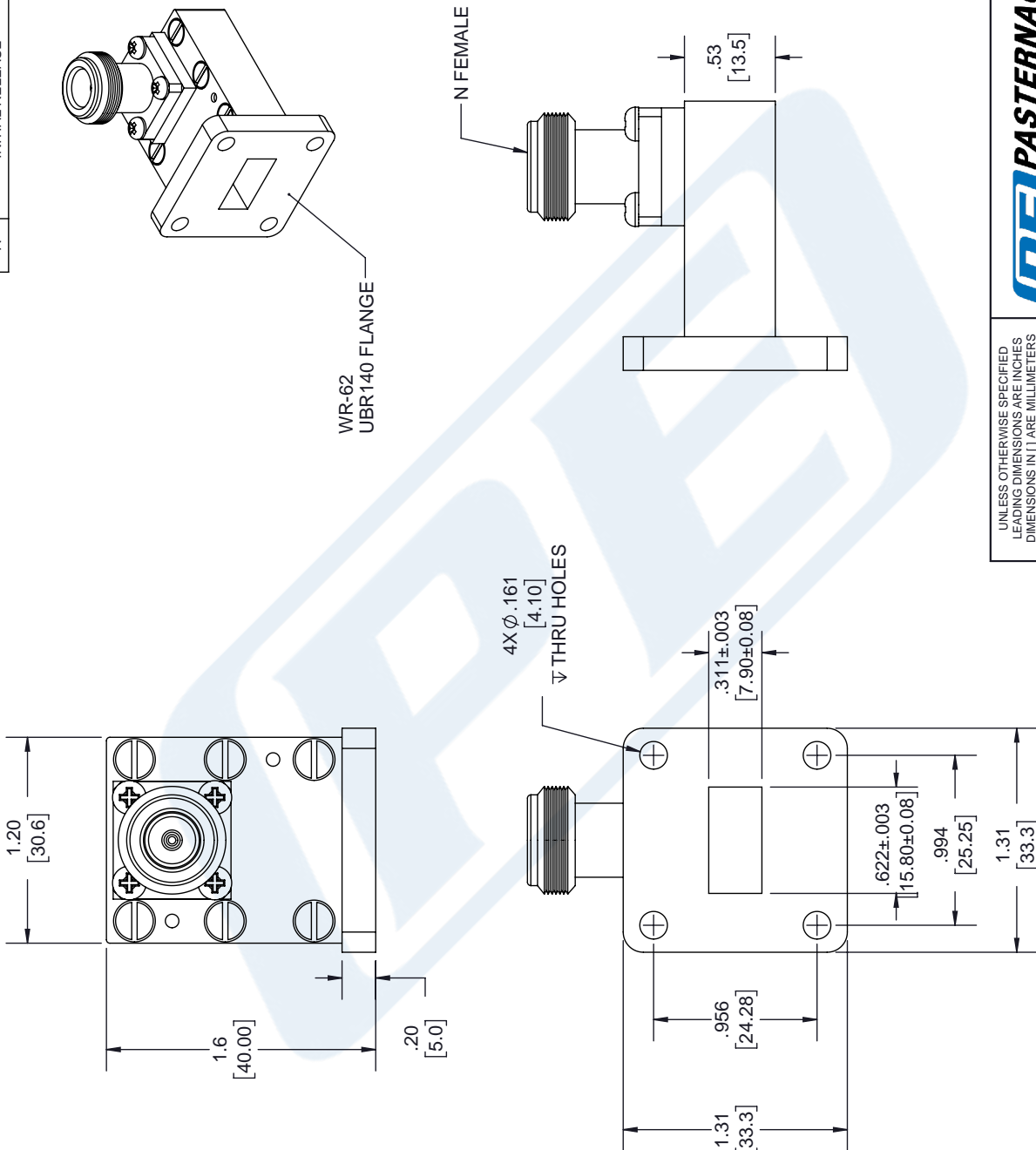

WR-62
UBR140 FLANGE

N FEMALE

4X Ø .161
[4.10]
▽ THRU HOLES

LABEL:
PASTERNAK
PEWCA1097
D/C: YYWW

UNLESS OTHERWISE SPECIFIED
LEADING DIMENSIONS ARE INCHES
DIMENSIONS IN [] ARE MILLIMETERS

TOLERANCES:
 .X = ±.2 [5.08] FRACTIONS ± 1/32
 .XX = ±.02 [.51] ANGLES ± 1°
 .XXX = ±.005 [.13]

CABLE LENGTH (L) TOLERANCES:
 L ≤ 12 [305] = +1 [25] / -0
 12 [305] < L ≤ 60 [1524] = +2 [51] / -0
 60 [1524] < L ≤ 120 [3048] = +4 [102] / -0
 120 [3048] < L ≤ 300 [7620] = +6 [152] / -0
 300 [7620] < L = +5%L / -0

ALL DIMENSIONS SHOWN
ARE FOR REFERENCE ONLY.

PE PASTERNAK
an INFINITI brand

Pasternack Enterprises, Inc.
P. O. Box 16759, Irvine, CA 92623.
Phone: 1.949.261.1920 | 1.866.727.8376
Fax: 1.949.261.7451
Website: www.pasternack.com
E-mail: sales@pasternack.com

SIZE A CAGE CODE 53919 DRAWN BY BPUCHASKI ITEM NO. PEWCA1097

THIRD-ANGLE PROJECTION

THE INFORMATION AND DESIGN IN THIS DOCUMENT IS THE PROPERTY OF PASTERNAK CORPORATION ALL RIGHTS RESERVED.

SHEET 1 OF 1

SCALE N/A

REV A

THESE COMMODITIES, TECHNOLOGY OR SOFTWARE WERE EXPORTED FROM THE UNITED STATES IN ACCORDANCE WITH THE EXPORT ADMINISTRATION REGULATIONS. DIVERSION CONTRARY TO U.S. LAW PROHIBITED.