



WR-12 Waveguide Shim, UG-Cover Round flange, 2mm Brass

Waveguide Accessories Technical Data Sheet

PEW12FS2

Features

- WR-12 Waveguide Shim
- Round UG-Cover Flange Configuration
- Frequency Range: 60.5 GHz to 91.9 GHz
- 2 mm Thick Brass Construction

Description

PEW12FS2 is a WR-12 waveguide shim with operating frequency range from 60.5 GHz to 91.9 GHz. This waveguide shim is fabricated with 2 mm thick brass by high precision manufacturing process. PEW12FS2 can be used to bridge gaps between WR-12 waveguide components with UG-Cover Round flanges. Pasternack offers wide selection of waveguide components with high performance available in stock and same-day shipping to customers worldwide.

Mechanical Specifications

| | |
|---------------|---------------------|
| Body Material | Brass |
| Body Finish | Gold plating |
| Length | 0.079 in [2.01][mm] |
| Width | 0.752 in [19.1][mm] |
| Height | 0.752 in [19.1][mm] |
| Weight | 0.22 lbs [99.79][g] |

Compliance Certifications (see [product page](#) for current document)

WR-12 Waveguide Shim, UG-Cover Round flange, 2mm Brass from Pasternack Enterprises has same day shipment for domestic and International orders. Our RF, microwave and millimeter wave products maintain a 99.4% availability and are part of the broadest selection in the industry.

Click the following link (or enter part number in "SEARCH" on website) to obtain additional part information including price, inventory and certifications: [WR-12 Waveguide Shim, UG-Cover Round flange, 2mm Brass PEW12FS2](#)

URL: <https://www.pasternack.com/pew12fs2-p.aspx>

The information contained in this document is accurate to the best of our knowledge and representative of the part described herein. It may be necessary to make modifications to the part and/or the documentation of the part, in order to implement improvements. Pasternack reserves the right to make such changes as required. Unless otherwise stated, all specifications are nominal. Pasternack does not make any representation or warranty regarding the suitability of the part described herein for any particular purpose, and Pasternack does not assume any liability arising out of the use of any part or documentation.

PEW12FS2 CAD Drawing

WR-12 Waveguide Shim, UG-Cover Round flange, 2mm Brass

| REV. | DESCRIPTION | DATE | APPROVED |
|------|-----------------|-----------|----------|
| A | INITIAL RELEASE | 1/28/2020 | S-PONG |

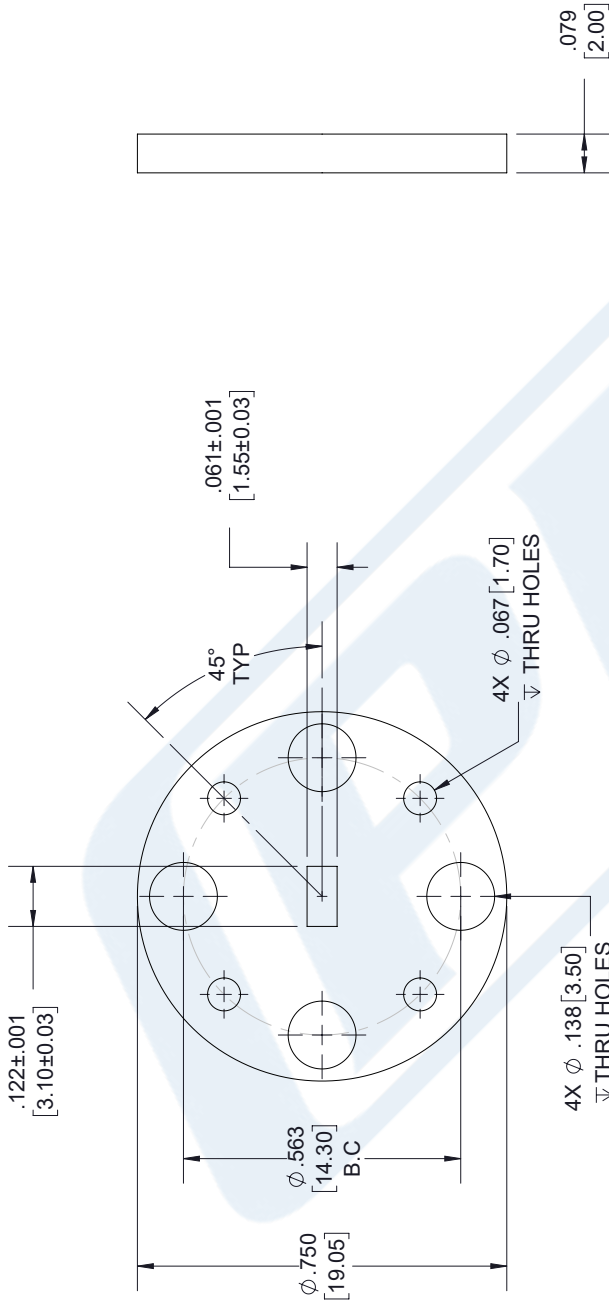

WR-12 WAVEGUIDE
UG-387/U ROUND COVER FLANGE

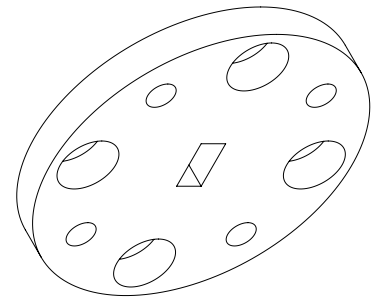

UNLESS OTHERWISE SPECIFIED
LEADING DIMENSIONS ARE INCHES
DIMENSIONS IN [] ARE MILLIMETERS

TOLERANCES:
 .X = ± .2 [5.08] FRACTIONS ± 1/32
 .XX = ± .02 [.51] ± .005 [.13] ANGLES ± 1°
 .XXX = ± .005 [.13] CABLE LENGTH (L) TOLERANCES:
 L ≤ 12 [305] = +1 [25] / -0
 12 [305] < L ≤ 60 [1524] = +2 [51] / -0
 60 [1524] < L ≤ 120 [3048] = +4 [102] / -0
 120 [3048] < L ≤ 300 [7620] = +6 [152] / -0
 300 [7620] < L = +5% / L / -0

ALL DIMENSIONS SHOWN
ARE FOR REFERENCE ONLY.

THIRD-ANGLE PROJECTION

THE INFORMATION AND
DESIGN IN THIS DOCUMENT
IS THE PROPERTY OF
PASTERNAK CORPORATION
ALL RIGHTS RESERVED.

SHEET 1 OF 1

SCALE N/A

REV A

ITEM NO. PEW12FS2

SIZE A CAGE CODE 53919 DRAWN BY K.DANG

PE PASTERNAK
an INFINITO brand

Pasternack Enterprises, Inc.
P. O. Box 16759, Irvine, CA 92623.
Phone: 1.949.261.1920 | 1.866.727.8376
Fax: 1.949.261.7451
Website: www.pasternack.com
E-mail: sales@pasternack.com

THESE COMMODITIES, TECHNOLOGY OR SOFTWARE WERE EXPORTED FROM THE UNITED STATES IN ACCORDANCE WITH THE EXPORT ADMINISTRATION REGULATIONS. DIVERSION CONTRARY TO U.S. LAW PROHIBITED.