



Aluminum Alloy Yagi Antenna with  
144 to 148 MHz and 300 to 450 MHz, 9.5/11.5 dBi, N  
Female, Vertical Polarization, 1 Port, 1.5 VSWR

## Antennas Technical Data Sheet

**PEANYG1000**

### Features

- Frequency coverage for 144 MHz to 148 MHz and 300 MHz to 450 MHz with Type N Female connector and gain 9.5 dBi / 11.5 dBi antennas
- Covers 2-Meter amateur band of 145MHz VHF band
- Easy and quick time to installations with small packaging
- Weather and corrosion free made of high-grade aluminum alloys
- 100 W max input power
- Vertical Polarization

### Applications

- Outdoor point-to-point (PtP) or point-to-multipoint (PtMP) applications
- 2-meter band applications of 145MHz band
- VHF/UHF radio applications supported with Trunking for two-way radio communications
- Public Safety / Emergency services / Marine communications / Rail road communications
- Tetra and P-25 Applications exclusively supported
- Land Mobile Radio (LMR) and Private Mobile Radio (PMR)
- Fixed and mobile services for paging/voice/data in full duplex and half duplex mode

### Description

Pasternack's PEANYG1000 9.5/11.5 dBi aluminum alloy yagi antenna, with N female connector, is an economical yet high-performance antenna designed for high-power applications. This high gain 9.5/11.5 dBi antenna transmits high-power signals, increasing the signal strength and thus providing improved coverage, better-broadcast control, and faster speed. This yagi antenna can output frequencies from 144 to 148 and 300 to 450 MHz, which is useful for military communications, trunking, public safety, industrial communication, and amateur radio applications.

Pasternack's PEANYG1000 yagi antenna elements are compactly packaged, thus transportation and installation become easier. It has a 1.5 VSWR that results in the best power transfer and reduced losses. This 144 to 148 and 300 to 450 MHz VHF/UHF antenna made from strong and lightweight aluminum alloy has high directional characteristics. This yagi antenna uses vertical polarization to transmit signals, thus reducing interference and performing better at lower heights. PEANYG1000 comes with a N female connector, which is threaded and weatherproof that ensuring a reliable physical connection. The yagi antenna has 1 port to connect an external circuit with 100W maximum input power per port. All components of this 9.5/11.5 dBi antenna are DC grounded for lightning protection, rugged outdoor design, and have a high-power handling capacity .

Pasternack's PEANYG1000 antenna with a 9.5/11.5 dBi maximum gain is ideal for LMR, military, airports, construction, mining, commercial applications, and radio users. Aluminum alloy yagi antenna from Pasternack comes in compact packaging for lower shipping costs. Pasternack's 144 to 148 and 300 to 450 MHz, 9.5/11.5 dBi aluminum alloy yagi antenna with a N female connector is in stock and ready to ship the same day. Contact Pasternack's knowledgeable and friendly technical support and sales staff for your answers on antennas or other products.

### Configuration

Design	Yagi
Band Type	Dual
Radiation Pattern	Directional
Polarization	Vertical
Connector Type	N Female
Number of Ports	1
Lightning Protection	DC Ground

Click the following link (or enter part number in "SEARCH" on website) to obtain additional part information including price, inventory and certifications: [Aluminum Alloy Yagi Antenna with 144 to 148 MHz and 300 to 450 MHz, 9.5/11.5 dBi, N Female, Vertical Polarization, 1 Port, 1.5 VSWR PEANYG1000](#)

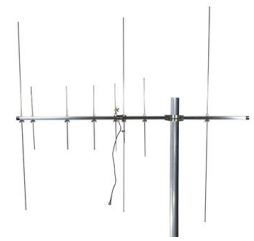

Aluminum Alloy Yagi Antenna with  
144 to 148 MHz and 300 to 450 MHz, 9.5/11.5 dBi, N  
Female, Vertical Polarization, 1 Port, 1.5 VSWR

## Antennas Technical Data Sheet

**PEANYG1000**

### Electrical Specifications

Description	Minimum	Typical	Maximum	Units
Input VSWR			1.5:1	
Impedance		50		Ohms
Input Power			100	Watts

### Specifications by Band

Description	Band 1	Band 2	Band 3	Band 4	Band 5	Units
Range	0.144 to 0.148	0.3 to 0.45				GHz
Gain	9.5	11.5				dBi

### Mechanical Specifications

Radome Material	Aluminum Alloy				
<b>Size</b>					
Overall Length	43.4 in [110.24 cm]				
Width	21.7 in [551.18 mm]				
Height	2 in [50.8 mm]				
Weight	22 lbs [9.98 kg]				

### Environmental Specifications

<b>Temperature</b>					
Operating Range	-40 to +80 deg C				

**Compliance Certifications** (see [product page](#) for current document)

### Plotted and Other Data

Notes:

Click the following link (or enter part number in "SEARCH" on website) to obtain additional part information including price, inventory and certifications: [Aluminum Alloy Yagi Antenna with 144 to 148 MHz and 300 to 450 MHz, 9.5/11.5 dBi, N Female, Vertical Polarization, 1 Port, 1.5 VSWR PEANYG1000](#)



Aluminum Alloy Yagi Antenna with  
144 to 148 MHz and 300 to 450 MHz, 9.5/11.5 dBi, N  
Female, Vertical Polarization, 1 Port, 1.5 VSWR

## Antennas Technical Data Sheet

**PEANYG1000**

Aluminum Alloy Yagi Antenna with 144 to 148 MHz and 300 to 450 MHz, 9.5/11.5 dBi, N Female, Vertical Polarization, 1 Port, 1.5 VSWR from Pasternack Enterprises has same day shipment for domestic and International orders. Our RF, micro-wave and millimeter wave products maintain a 99.4% availability and are part of the broadest selection in the industry.

Click the following link (or enter part number in "SEARCH" on website) to obtain additional part information including price, inventory and certifications: [Aluminum Alloy Yagi Antenna with 144 to 148 MHz and 300 to 450 MHz, 9.5/11.5 dBi, N Female, Vertical Polarization, 1 Port, 1.5 VSWR PEANYG1000](https://www.pasternack.com/antenna-n-type-female-connector-peanyg1000-p.aspx)

URL: <https://www.pasternack.com/antenna-n-type-female-connector-peanyg1000-p.aspx>

The information contained in this document is accurate to the best of our knowledge and representative of the part described herein. It may be necessary to make modifications to the part and/or the documentation of the part, in order to implement improvements. Pasternack reserves the right to make such changes as required. Unless otherwise stated, all specifications are nominal. Pasternack does not make any representation or warranty regarding the suitability of the part described herein for any particular purpose, and Pasternack does not assume any liability arising out of the use of any part or documentation.

# PEANYG1000 CAD Drawing

Aluminum Alloy Yagi Antenna with 144 to 148 MHz and 300 to 450 MHz,  
9.5/11.5 dBi, N Female, Vertical Polarization, 1 Port, 1.5 VSWR

REVISIONS			
REV.	DESCRIPTION	DATE	APPROVED
A	INITIAL RELEASE	5/5/2022	KHIETPAS

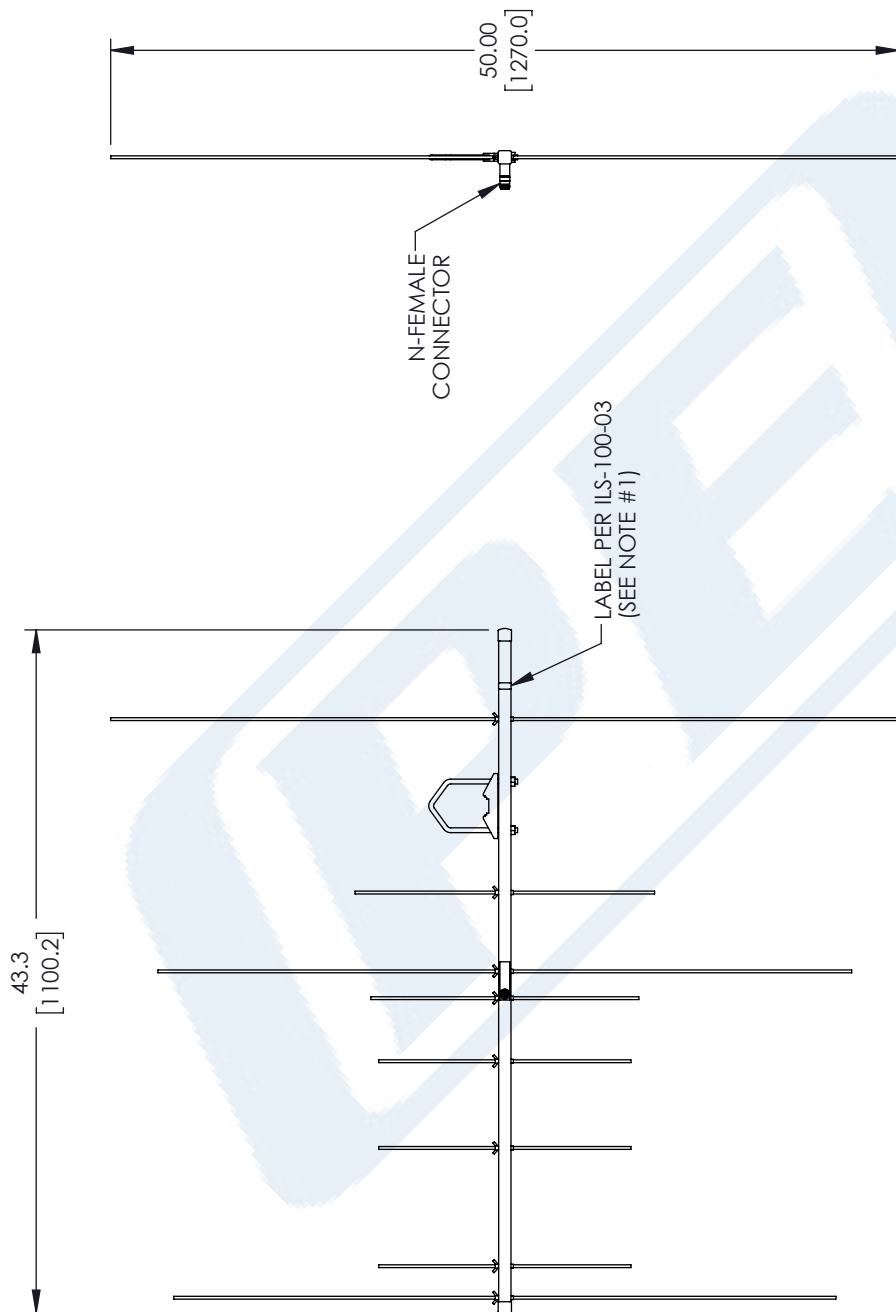

THIRD-ANGLE PROJECTION

THE INFORMATION AND DESIGN IN THIS DOCUMENT IS THE PROPERTY OF PASTERNAK CORPORATION. ALL RIGHTS RESERVED.

SHEET 1 OF 1

SCALE N/A

REV A

---

**PE PASTERNAK**  
an INFINITI® brand

Pasternack Enterprises, Inc.  
P.O. Box 16759, Irvine, CA 92623,  
Phone: 1.949.261.1920 | 1.866.727.8376  
Fax: 1.949.261.7451  
Website: www.pasternack.com  
E-mail: sales@pasternack.com

ITEM NO. PEANYG1000

SIZE A CAGE CODE 53919 DRAWN BY DMAY

---

UNLESS OTHERWISE SPECIFIED LEADING DIMENSIONS ARE INCHES DIMENSIONS IN [ ] ARE MILLIMETERS

TOLERANCES:

X ± .2	[5.08]	FRACTIONS
XX ± .02	[.51]	± 1/32
XXX ± .005	[.13]	ANGLES ± 1°

CABLE LENGTH (L) TOLERANCES:

L ≤ 12 [305]	± .1 [2.5]	/ - 0
12 [305] < L ≤ 60 [1524]	± .2 [5.1]	/ - 0
60 [1524] < L ≤ 120 [3048]	± .4 [10.2]	/ - 0
120 [3048] < L ≤ 300 [7620]	± .6 [15.2]	/ - 0
300 [7620] < L	± 5%	/ - 0

ALL DIMENSIONS SHOWN ARE FOR REFERENCE ONLY.

- NOTES:
- LABEL PER ILS-100-03 (FOR INTERNAL REFERENCE ONLY). LABEL LOCATION FOR REFERENCE ONLY.

THESE COMMODITIES, TECHNOLOGY OR SOFTWARE WERE EXPORTED FROM THE UNITED STATES IN ACCORDANCE WITH THE EXPORT ADMINISTRATION REGULATIONS. DIVERSION CONTRARY TO U.S. LAW PROHIBITED.