



902 to 928 MHz, RFID Flat Panel Antenna, 5 dBi Gain, Type N Male, EVA Radome, RHCP

Antennas Technical Data Sheet

PEANFP1067

Features

- High Performance Multi-tag read/write Capabilities
- Lightweight, Concealable Design
- Right Hand Circular Polarized
- 902 to 928 MHz Frequency Range
- 2 Meter Cable
- Type N Male Connector

Applications

- Radio Frequency Identification
- Inventory Management
- Access Control
- Data Collection
- Asset Tracking
- Livestock Management

Description

Pasternack's PEANFP1067 is a RHCP RFID flat panel antenna. The PEANFP1067 with a 5 dBi gain nominal is a Directional antenna. Our 902 to 928 MHz antenna has N Male connector.

With an impedance of 50 Ohms and max input power of 20 Watts, the PEANFP1067 flat panel RHCP antenna is well suited for Radio Frequency Identification tag reading applications. This 902-928 MHz 5 dBi gain RFID antenna is highly directional providing the reader radio the capabilities of simultaneously reading a multitude of RFID tags with a high degree of accuracy.

Pasternack's RFID PEANFP1067 has a radome made of EVA in Black color and comes from a facility certified to ISO 9001:2015. This N Male connectized Antenna has an overall length of 20 in, width of 13.7 in, and weighs 1 lbs. Use our on-line ordering system to purchase your PEANFP1067 RFID Directional RHCP antenna 24 hours a day with same-day shipping and no MOQs (minimum order quantities).

Configuration

Design	Flat Panel
Application Band	RFID
Band Type	Single
Radiation Pattern	Directional
Polarization	RHCP
Cable Type	RG316
Connector Type	N Male
Lightning Protection	DC Grounded

Electrical Specifications

Description	Minimum	Typical	Maximum	Units
Frequency Range	902		928	MHz
Input VSWR			1.5:1	
Impedance		50		Ohms
Gain		5		dBi
Front to Back Ratio		20		dB
Horizontal (Azimuth) Beam Width		45		Degrees
Vertical (Elevation) Beam Width		30		Degrees
Input Power			20	Watts

Click the following link (or enter part number in "SEARCH" on website) to obtain additional part information including price, inventory and certifications: [902 to 928 MHz, RFID Flat Panel Antenna, 5 dBi Gain, Type N Male, EVA Radome, RHCP PEANFP1067](#)



902 to 928 MHz, RFID Flat Panel Antenna, 5 dBi Gain, Type N Male, EVA Radome, RHCP

Antennas Technical Data Sheet

PEANFP1067

Mechanical Specifications

Radome Material	EVA
Size	
Overall Length	20 in [508 mm]
Width	13.7 in [347.98 mm]
Height	0.19 in [4.83 mm]
Weight	1 lbs [453.59 g]

Connectors

Description	Connector 1	Connector 2	Connector 3
Body Material and Plating	Brass, Nickel		

Environmental Specifications

Temperature	
Operating Range	-20 to +65 deg C

Compliance Certifications (see [product page](#) for current document)

Plotted and Other Data

Notes:

902 to 928 MHz, RFID Flat Panel Antenna, 5 dBi Gain, Type N Male, EVA Radome, RHCP from Pasternack Enterprises has same day shipment for domestic and International orders. Our RF, microwave and millimeter wave products maintain a 99.4% availability and are part of the broadest selection in the industry.

Click the following link (or enter part number in "SEARCH" on website) to obtain additional part information including price, inventory and certifications: [902 to 928 MHz, RFID Flat Panel Antenna, 5 dBi Gain, Type N Male, EVA Radome, RHCP PEANFP1067](#)

URL: <https://www.pasternack.com/5-dbi-flat-panel-antenna-902-928-mhz-n-type-male-connector-peanfp1067-p.aspx>

The information contained in this document is accurate to the best of our knowledge and representative of the part described herein. It may be necessary to make modifications to the part and/or the documentation of the part, in order to implement improvements. Pasternack reserves the right to make such changes as required. Unless otherwise stated, all specifications are nominal. Pasternack does not make any representation or warranty regarding the suitability of the part described herein for any particular purpose, and Pasternack does not assume any liability arising out of the use of any part or documentation.

PEANFP1067 CAD Drawing

902 to 928 MHz, RFID Flat Panel Antenna, 5 dBi Gain, Type N Male, EVA Radome, RHCP

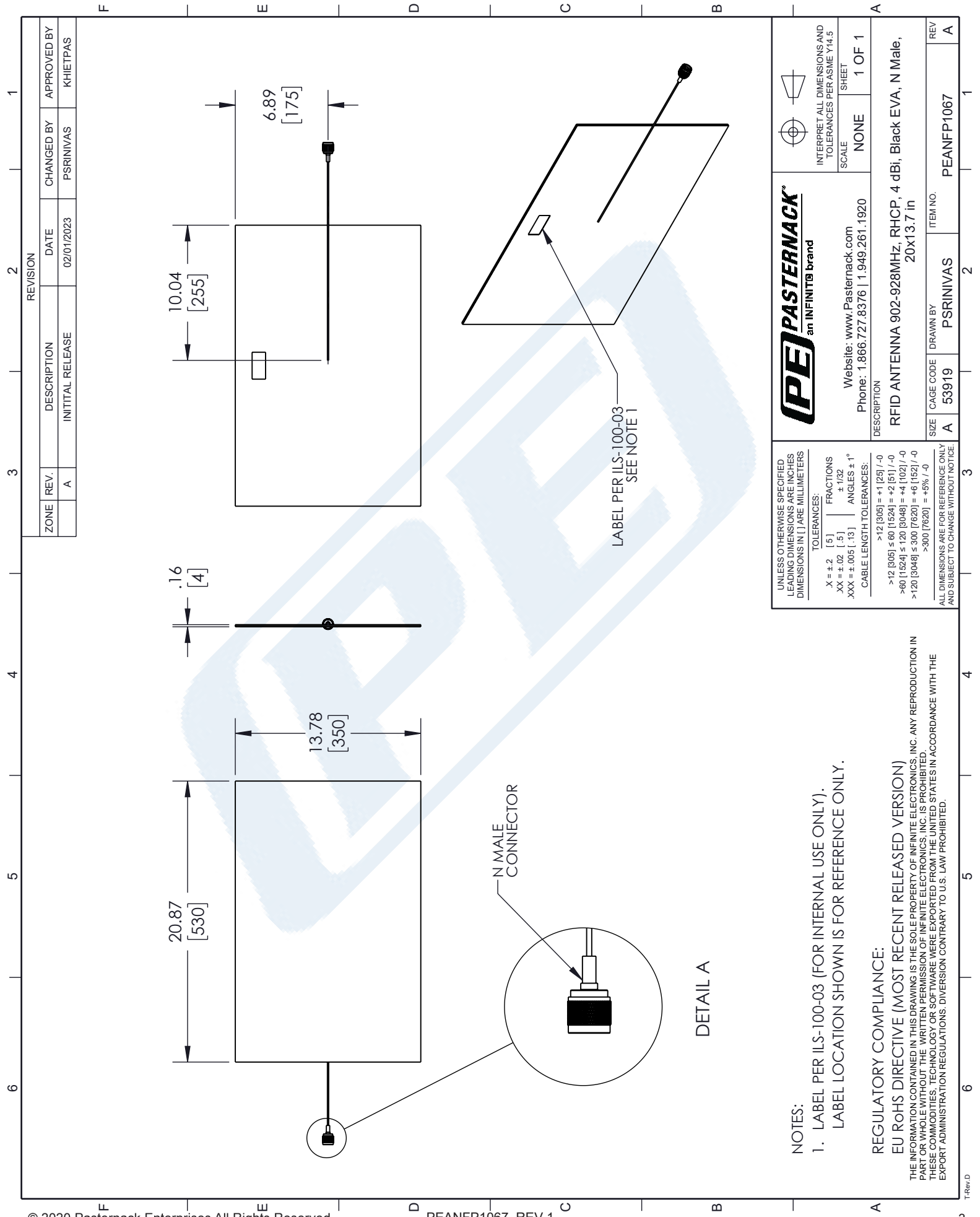

ZONE		REVISION		CHANGED BY		APPROVED BY	
REV.	DESCRIPTION	DATE		PSRINIVAS		KHIETPAS	
A	INITIAL RELEASE	02/01/2023					

		INTERPRET ALL DIMENSIONS AND TOLERANCES PER ASME Y14.5 SCALE NONE SHEET 1 OF 1	
Website: www.Pasternack.com Phone: 1.866.727.8376 1.949.261.1920		DESCRIPTION RFID ANTENNA 902-928MHz, RHCP, 4 dBi, Black EVA, N Male, 20x13.7 in	
SIZE A	CAGE CODE 53919	DRAWN BY PSRINIVAS	ITEM NO. PEANFP1067
UNLESS OTHERWISE SPECIFIED LEADING DIMENSIONS ARE INCHES DIMENSIONS IN [] ARE MILLIMETERS TOLERANCES: X = ±.2 [5] FRACTIONS ±.02 [.5] ±.1/32 XXX = ±.005 [.13] ANGLES ± 1° CABLE LENGTH TOLERANCES: >12 [305] = +1 [25] / -0 >12 [305] ≤ 60 [1524] = +2 [51] / -0 >60 [1524] ≤ 120 [3048] = +4 [102] / -0 >120 [3048] ≤ 300 [7620] = +6 [192] / -0 >300 [7620] = +5% / -0 ALL DIMENSIONS ARE FOR REFERENCE ONLY AND SUBJECT TO CHANGE WITHOUT NOTICE			

NOTES:

1. LABEL PER ILS-100-03 (FOR INTERNAL USE ONLY). LABEL LOCATION SHOWN IS FOR REFERENCE ONLY.

REGULATORY COMPLIANCE:

EU ROHS DIRECTIVE (MOST RECENT RELEASED VERSION)
 THE INFORMATION CONTAINED IN THIS DRAWING IS THE SOLE PROPERTY OF INFINITE ELECTRONICS, INC. ANY REPRODUCTION IN PART OR WHOLE WITHOUT THE WRITTEN PERMISSION OF INFINITE ELECTRONICS, INC. IS PROHIBITED.
 THESE COMMODITIES, TECHNOLOGY OR SOFTWARE WERE EXPORTED FROM THE UNITED STATES IN ACCORDANCE WITH THE EXPORT ADMINISTRATION REGULATIONS. DIVERSION CONTRARY TO U.S. LAW PROHIBITED.