

WR-102 Waveguide Standard Gain Horn Antenna, 7 GHz to 11 GHz Frequency Range, 15 dBi Gain, Flange

Waveguide Antennas Technical Data Sheet

PE9857B-15

Features

- WR-102 Rectangular Waveguide Interface
- 7 GHz to 11 GHz
- 15 dBi Nominal Gain
- square Cover Flange

Applications

- Antenna Measurements
- Wireless Communication
- Laboratory Use
- Microwave Radio Systems

Description

The PE9857B-15 WR-102 Proline series standard gain horn antenna (also known as waveguide horn) from Pasternack has a nominal gain of 15 dBi. This WR-102 standard gain horn has a square type flange. The Pasternack 15 dBi WR-102 horn antenna operates from 7 GHz to 11 GHz. The WR-102 PE9857B-15 waveguide horn is US made and TAA compliant. It is part of over 40,000 RF, microwave and millimeter wave components available from Pasternack. Waveguide standard gain horn antennas are used in a wide variety of applications due to their high power handling capability, low loss, high directivity, and near constant electrical performance. Pasternack's WR-102 standard gain horns are available in 10, 15 and 20 dBi models with pyramidal shape and rectangular input. Our WR-102 standard gain horn Proline antennas can ship worldwide the same day as it is purchased as with our other available RF parts.

Configuration

Design	WR-102 Standard Gain Horn
Pattern	Directional
Polarization	Linear

Electrical Specifications

Description	Minimum	Typical	Maximum	Units
Frequency Range	7		11	GHz
Nominal Gain		15		dB
VSWR		1.5:1		

Mechanical Specifications

Size	
Length	5.08 in [129.03 mm]
Width	2.82 in [71.63 mm]
Height	2.09 in [53.09 mm]
Weight	0.05 lbs [22.68 g]

Waveguide Interface

Waveguide Size	WR-102
Flange Type	Square Cover

Click the following link (or enter part number in "SEARCH" on website) to obtain additional part information including price, inventory and certifications: [WR-102 Waveguide Standard Gain Horn Antenna, 7 GHz to 11 GHz Frequency Range, 15 dBi Gain, Flange PE9857B-15](#)

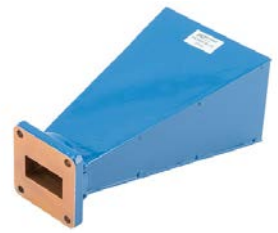

WR-102 Waveguide Standard Gain Horn Antenna, 7 GHz
to 11 GHz Frequency Range, 15 dBi Gain, Flange

Waveguide Antennas Technical Data Sheet

PE9857B-15

Body Material and Plating

Aluminum

Compliance Certifications (see [product page](#) for current document)

Plotted and Other Data

WR-102 Waveguide Standard Gain Horn Antenna, 7 GHz to 11 GHz Frequency Range, 15 dBi Gain, Flange from Pasternack Enterprises has same day shipment for domestic and International orders. Our RF, microwave and millimeter wave products maintain a 99.4% availability and are part of the broadest selection in the industry.

Click the following link (or enter part number in "SEARCH" on website) to obtain additional part information including price, inventory and certifications: [WR-102 Waveguide Standard Gain Horn Antenna, 7 GHz to 11 GHz Frequency Range, 15 dBi Gain, Flange PE9857B-15](#)

URL: <https://www.pasternack.com/wr-102-waveguide-gain-horn-antenna-15db-square-flange-pe9857b-15-p.aspx>

The information contained in this document is accurate to the best of our knowledge and representative of the part described herein. It may be necessary to make modifications to the part and/or the documentation of the part, in order to implement improvements. Pasternack reserves the right to make such changes as required. Unless otherwise stated, all specifications are nominal. Pasternack does not make any representation or warranty regarding the suitability of the part described herein for any particular purpose, and Pasternack does not assume any liability arising out of the use of any part or documentation.

PE9857B-15 CAD Drawing

WR-102 Waveguide Standard Gain Horn Antenna, 7 GHz to 11 GHz Frequency Range, 15 dBi Gain, Flange

REVISIONS			
REV.	DESCRIPTION	DATE	APPROVED
B	PCR	04/01/2022	KHIETPAS

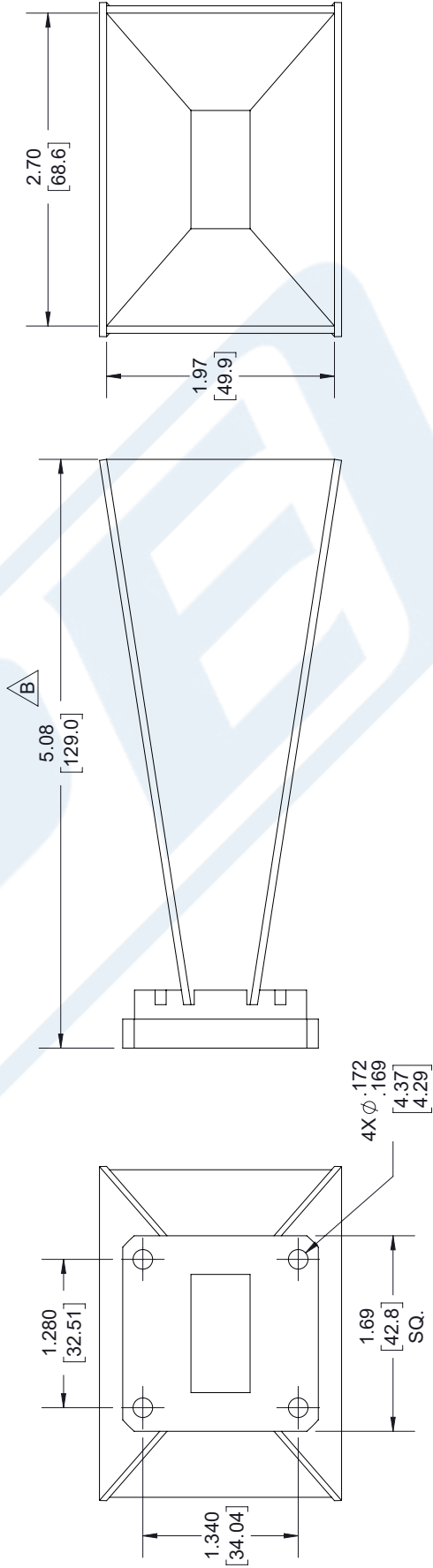
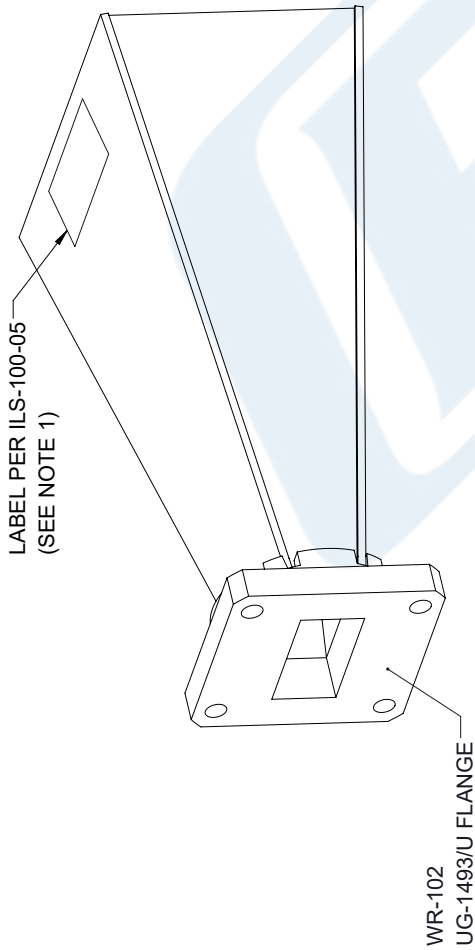

THIRD-ANGLE PROJECTION

THE INFORMATION AND DESIGN IN THIS DOCUMENT IS THE PROPERTY OF PASTERNAK CORPORATION. ALL RIGHTS RESERVED.

SHEET 1 OF 1

SCALE N/A

REV B

PE PASTERNAK
an INFINITI brand

Pasternack Enterprises, Inc.
P. O. Box 16759, Irvine, CA 92623.
Phone: 1.949.261.1920 | 1.866.727.8376
Fax: 1.949.261.7451
Website: www.pasternack.com
E-mail: sales@pasternack.com

ITEM NO. PE9857B-15

UNLESS OTHERWISE SPECIFIED LEADING DIMENSIONS ARE INCHES DIMENSIONS IN [] ARE MILLIMETERS

TOLERANCES:

.X = ±.2 [5.08] FRACTIONS ±.1/32
.XX = ±.02 [.51] ±.1/32
.XXX = ±.005 [.13] ANGLES ± 1°

CABLE LENGTH (L) TOLERANCES:
L ≤ 12 [305] = +1 [25] / -0
12 [305] < L ≤ 60 [1524] = +2 [51] / -0
60 [1524] < L ≤ 120 [3048] = +4 [102] / -0
120 [3048] < L ≤ 300 [7620] = +6 [152] / -0
300 [7620] < L = +5% / -0

ALL DIMENSIONS SHOWN ARE FOR REFERENCE ONLY.

SIZE [CAGE CODE] DRAWN BY ITEM NO.

A 53919 BPUCHASKI PE9857B-15

NOTES:
1. LABEL PER ILS-100-05 (FOR INTERNAL REFERENCE ONLY)
LABEL LOCATION FOR REFERENCE ONLY

THESE COMMODITIES, TECHNOLOGY OR SOFTWARE WERE EXPORTED FROM THE UNITED STATES IN ACCORDANCE WITH THE EXPORT ADMINISTRATION REGULATIONS. DIVERSION CONTRARY TO U.S. LAW PROHIBITED.