



Low PIM 7/16 DIN Female to 4.3-10 Male QD Adapter

RF Adapters Technical Data Sheet

PE91472

Configuration

- 7/16 DIN Female Connector 1
- QD 4.3-10 Male Connector 2
- 50 Ohm
- Low PIM Design
- Straight Body Geometry

Features

- Max VSWR of 1.2:1 up to 6 GHz
- PIM levels lower than -163 dBc
- Silver Plated Beryllium Copper Contact
- Quick Disconnect (QD) on the 4.3-10 Interface

Applications

- Allows Connection Between Series
- General Purpose Test
- Low PIM Applications
- Mobile Communications Systems
- Base Stations
- Distributed Antenna Systems (DAS)
- Small Cells
- Feeder Cables

Description

Pasternack's PE91472 7/16 DIN female to 4.3-10 male QD adapter is part of our full line of RF components available for same-day shipping. Our 7/16 DIN to 4.3-10 adapter has a female to male gender configuration in a low PIM design. PE91472 7/16 DIN female to 4.3-10 male adapter operates to 6 GHz. The Pasternack RF adapter provides excellent VSWR of 1.2:1 maximum and passive intermodulation of -163 dBc maximum.

RF adapters are often used to enable connections between two connector types that would otherwise not mate. Certain adapter configurations can also be used to protect connectors on expensive equipment where the number of connect/disconnect cycles is high. An RF, microwave or millimeter wave adapter is connected to the equipment, and the commonly changed connection is made with the adapter which can be easily replaced when it wears out after high usage; such adapters are referred to as connector savers. Pasternack also offers bulkhead, panel mount, hermetically sealed, reverse polarity, and isolated ground adapter varieties to serve all of your RF, microwave and millimeter wave needs.

Electrical Specifications

Description	Minimum	Typical	Maximum	Units
Frequency Range	DC		6	GHz
VSWR			1.2:1	
Passive Intermodulation			-163	dBc

Electrical Specification Notes:
Values at 25° C, sea level.

Click the following link (or enter part number in "SEARCH" on website) to obtain additional part information including price, inventory and certifications: [Low PIM 7/16 DIN Female to 4.3-10 Male QD Adapter PE91472](#)



Low PIM 7/16 DIN Female to 4.3-10 Male QD Adapter

RF Adapters Technical Data Sheet

PE91472

Mechanical Specifications

Size

Description	Connector 1	Connector 2
Type	7/16 DIN Female	4.3-10 Male
Polarity	Standard	Standard
Mating Cycles	500	500

Material Specifications

Description	Connector 1		Connector 2	
	Material	Plating	Material	Plating
Type	7/16 DIN Female		QD 4.3-10 Male	
Contact	Beryllium Copper	Silver	Beryllium Copper	Silver
Insulation	PTFE		PTFE	
Outer Conductor	Brass	Tri-Metal		
Body	Brass	Tri-Metal	Brass	Tri-Metal
Gasket			Silicone Rubber	
Coupling Nut			Brass	Tri-Metal

Environmental Specifications

Temperature

Operating Range -40 to +155 deg C

Compliance Certifications (see [product page](#) for current document)

Plotted and Other Data

Notes:

Click the following link (or enter part number in "SEARCH" on website) to obtain additional part information including price, inventory and certifications: [Low PIM 7/16 DIN Female to 4.3-10 Male QD Adapter PE91472](#)



Low PIM 7/16 DIN Female to 4.3-10 Male QD Adapter

RF Adapters Technical Data Sheet

PE91472

Low PIM 7/16 DIN Female to 4.3-10 Male QD Adapter from Pasternack Enterprises has same day shipment for domestic and International orders. Our RF, microwave and millimeter wave products maintain a 99.4% availability and are part of the broadest selection in the industry.

Click the following link (or enter part number in "SEARCH" on website) to obtain additional part information including price, inventory and certifications: [Low PIM 7/16 DIN Female to 4.3-10 Male QD Adapter PE91472](#)

URL: <https://www.pasternack.com/7-16-din-female-4.3-10-male-straight-adapter-pe91472-p.aspx>

The information contained in this document is accurate to the best of our knowledge and representative of the part described herein. It may be necessary to make modifications to the part and/or the documentation of the part, in order to implement improvements. Pasternack reserves the right to make such changes as required. Unless otherwise stated, all specifications are nominal. Pasternack does not make any representation or warranty regarding the suitability of the part described herein for any particular purpose, and Pasternack does not assume any liability arising out of the use of any part or documentation.

PE91472 CAD Drawing

Low PIM 7/16 DIN Female to 4.3-10 Male QD Adapter

REVISIONS		
REV.	DESCRIPTION	DATE
	INITIAL RELEASE	01/11/19
		APPROVED
		J.GARCIA

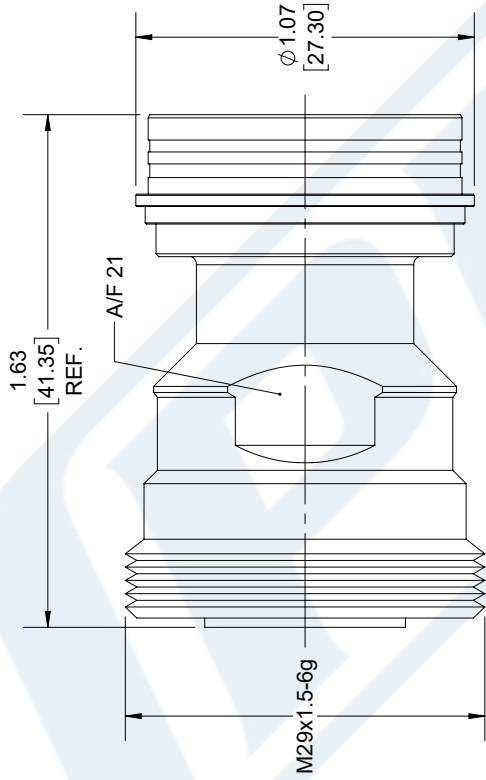

QUICK DISCONNECT
4.3-10
MALE

7/16
FEMALE

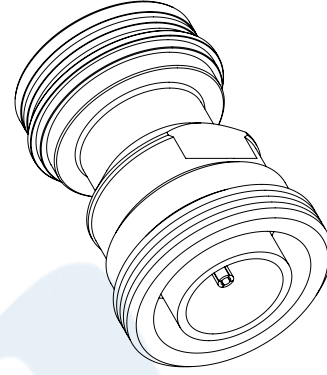

UNLESS OTHERWISE SPECIFIED LEADING DIMENSIONS ARE INCHES DIMENSIONS IN [] ARE MILLIMETERS	
TOLERANCES:	
X±.2 [5.08]	FRACTIONS
.XX±.01 [.25]	±.132
.XXX±.005 [.13]	ANGLES ± 1°
ALL DIMENSIONS SHOWN ARE FOR REFERENCE ONLY.	
THIRD-ANGLE PROJECTION	

PE PASTERNAK
an INFINITO brand

Pasternack Enterprises, Inc.
P.O. Box 16759, Irvine, CA 92623.
Phone: 1,949,261,1920 | 1,866,727,8376
Fax: 1,949,261,7451
www.pasternack.com | e-mail: sales@pasternack.com

THE INFORMATION AND DESIGN IN THIS DOCUMENT IS THE PROPERTY OF PASTERNAK CORPORATION. ALL RIGHTS RESERVED.

SHEET 1 OF 1
SCALE N/A

SIZE A CAGE 53919 DRAWN BY G.HUAN PART NUMBER PE91472 REV A

THESE COMMODITIES, TECHNOLOGY OR SOFTWARE WERE EXPORTED FROM THE UNITED STATES IN ACCORDANCE WITH THE EXPORT ADMINISTRATION REGULATIONS. DIVERSION CONTRARY TO U.S. LAW PROHIBITED.