



High Power Isolator With 20 dB Isolation From 450 MHz to 520 MHz, 150 Watts And N Female

Isolators Technical Data Sheet

PE8326

Features

- High Power
- 450 to 520 MHz Frequency Range
- Max Forward Power 150 Watts CW
- Max Reverse Power 70 Watts CW
- Insertion Loss < 0.5 dB
- VSWR < 1.25:1
- Isolation > 20 dB
- N Female Connectors

Applications

- Radar Systems
- Military
- Wireless Radio Systems
- Telecom Infrastructure
- Communication Systems
- R&D Labs
- Microwave Radio Systems

Description

The PE8326 is a high power single junction isolator offering a forward power rating of 150 Watts CW and reverse power rating of 70 Watts CW over an operational frequency band of 450 to 520 MHz. This coaxial isolator uses N female connectors on all ports and has a minimum of 20 dB isolation.

Pasternack offers a wide variety of isolators to fit your needs. These are two-port devices that transmit microwave or radio frequency power in one direction only and block the signal in the opposite direction. They can be thought of as a diode for RF energy. Isolators are used to isolate equipment from the effects of conditions outside of the equipment. For instance they are used to prevent a microwave source being detuned by a mismatched load. Pasternack's isolators feature excellent insertion loss, high isolation and reliability.

Electrical Specifications

Description	Minimum	Typical	Maximum	Units
Frequency Range	450		520	MHz
Impedance		50		Ohms
Insertion Loss			0.5	dB
Isolation	20			dB
VSWR			1.25:1	
Forward Power, CW			150	Watts
Reverse Power, CW			70	Watts

Electrical Specification Notes:
 Values at 25°C, sea level.

Mechanical Specifications

Size	
Length	3 in [76.2 mm]
Width	3 in [76.2 mm]
Height	1.2 in [30.48 mm]
Weight	0.74 lbs [335.66 g]

Click the following link (or enter part number in "SEARCH" on website) to obtain additional part information including price, inventory and certifications: [High Power Isolator With 20 dB Isolation From 450 MHz to 520 MHz, 150 Watts And N Female PE8326](#)



High Power Isolator With 20 dB Isolation From
450 MHz to 520 MHz, 150 Watts And N Female

Isolators Technical Data Sheet

PE8326

Configuration

Design	Single Junction
Direction	1 to 2
Package Style	Connectorized
Connector 1	N Female
Connector 2	N Female

Environmental Specifications

Temperature

Operating Range	-30 to +70 deg C
-----------------	------------------

Compliance Certifications (see [product page](#) for current document)

Plotted and Other Data

Notes:

High Power Isolator With 20 dB Isolation From 450 MHz to 520 MHz, 150 Watts And N Female from Pasternack Enterprises has same day shipment for domestic and International orders. Our RF, microwave and millimeter wave products maintain a 99% availability and are part of the broadest selection in the industry.

Click the following link (or enter part number in "SEARCH" on website) to obtain additional part information including price, inventory and certifications: [High Power Isolator With 20 dB Isolation From 450 MHz to 520 MHz, 150 Watts And N Female PE8326](#)

URL: <https://www.pasternack.com/50-ohm-n-isolator-450-520-mhz-150-watts-20-db-pe8326-p.aspx>

The information contained in this document is accurate to the best of our knowledge and representative of the part described herein. It may be necessary to make modifications to the part and/or the documentation of the part, in order to implement improvements. Pasternack reserves the right to make such changes as required. Unless otherwise stated, all specifications are nominal. Pasternack does not make any representation or warranty regarding the suitability of the part described herein for any particular purpose, and Pasternack does not assume any liability arising out of the use of any part or documentation.

PE8326 CAD Drawing

High Power Isolator With 20 dB Isolation From 450 MHz to 520 MHz, 150 Watts And N Female

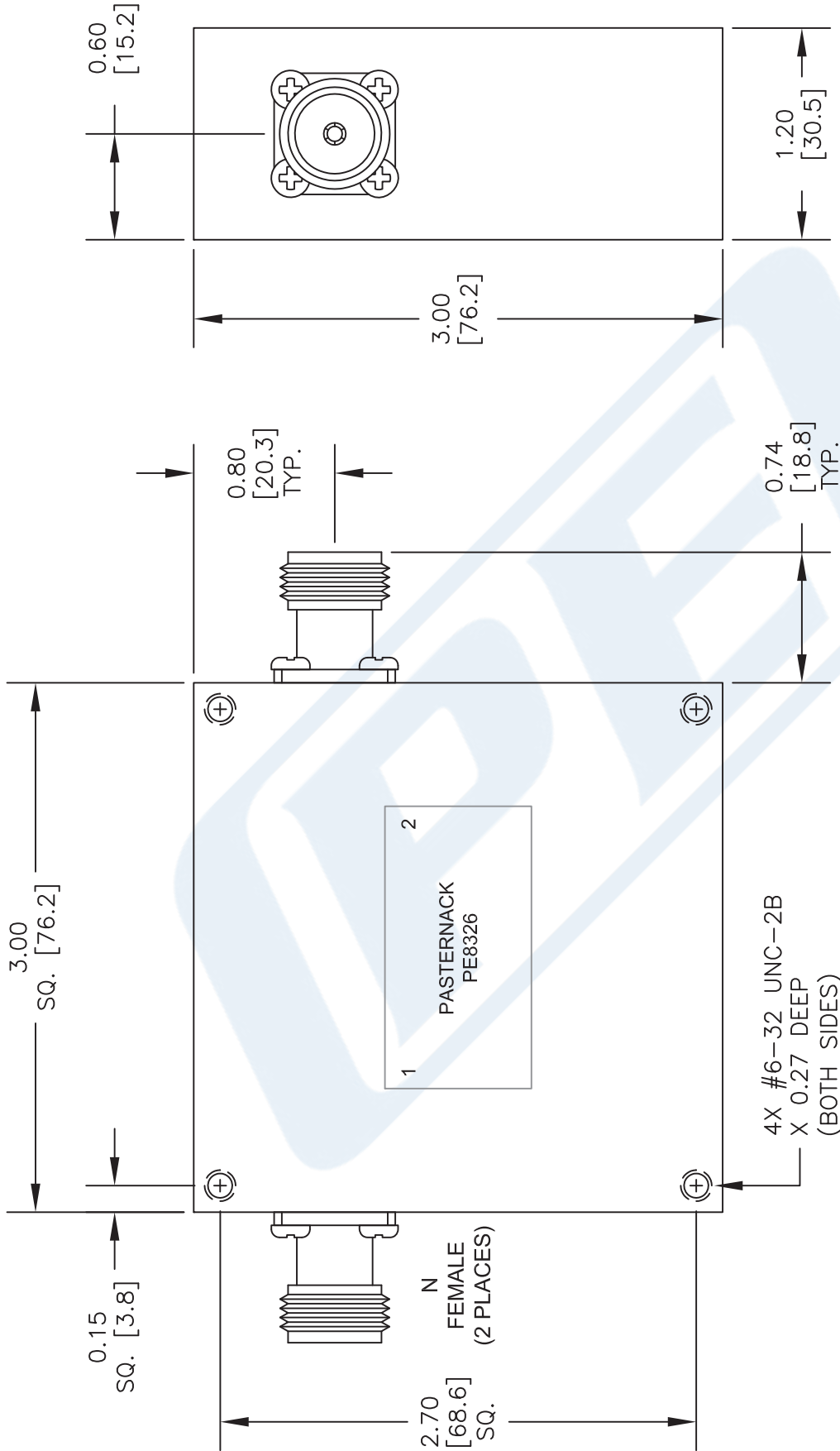

STANDARD TOLERANCES
 .X ±0.2
 .XX ±0.1
 .XXX ±0.05

*STANDARD TOLERANCES APPLY ONLY TO DIMENSIONS IN INCHES

NOTES:
 1. UNLESS OTHERWISE SPECIFIED ALL DIMENSIONS ARE NOMINAL.
 2. ALL SPECIFICATIONS ARE SUBJECT TO CHANGE WITHOUT NOTICE AT ANY TIME.
 3. DIMENSIONS ARE IN INCHES [mm].

DWG TITLE
PE8326

FSCM NO. 53919

CAD FILE 072916

SCALE N/A

SIZE A

2233

(PE) PASTERNAK®
 THE ENGINEER'S RF SOURCE
 Pasternack Enterprises, Inc.
 P.O. Box 16759 | Irvine | CA | 92623
 Phone: (949) 261-1920 | Fax: (949) 261-7451
 Website: www.pasternack.com | E-Mail: sales@pasternack.com