



DC Block on Inner and Outer Conductor 2.92mm Male to 2.92mm Female Operating From 10 MHz to 40 GHz

DC Blocks Technical Data Sheet

PE8227

Features

- Inner/Outer DC Block
- Operates from 10 MHz to 40 GHz
- Good Insertion Loss of 0.75 dB Max

Applications

- Test & Measurement
- Ground Loop Elimination
- Signal to Noise Ratio (SNR) Improvement

Description

Pasternack's PE8227 is an inner and outer DC block with 2.92mm connectors. It has a blocking capacitor on the inner and outer conductor and operates from 10 MHz to 40 GHz. Our 2.92mm DC block offers good insertion loss of 0.75 dB and has a maximum operating voltage of 200 Vdc. DC blocks are commonly used to filter out unwanted DC signals, while allowing AC drive signals to pass through. They can help improve signal to noise ratio (SNR), eliminate ground loops, or provide isolation in your test setup. All of Pasternack's DC blocks are in stock and available to ship same-day.

Electrical Specifications

Description	Minimum	Typical	Maximum	Units
Frequency Range	0.01		40	GHz
Impedance		50		Ohms
VSWR			1.45:1	
Insertion Loss			0.75	dB
Operating Voltage (DC)			200	Volts

Mechanical Specifications

Size

- Length 0.86 in [21.84 mm]
- Width 0.5 in [12.7 mm]
- Weight 0.013 lbs [5.9 g]
- Housing Material and Plating Plastic

Configuration

- Design Inner/Outer DC Block
- Package Type Connectorized

Click the following link (or enter part number in "SEARCH" on website) to obtain additional part information including price, inventory and certifications: [DC Block on Inner and Outer Conductor 2.92mm Male to 2.92mm Female Operating From 10 MHz to 40 GHz PE8227](#)



DC Block on Inner and Outer Conductor 2.92mm Male to 2.92mm Female Operating From 10 MHz to 40 GHz

DC Blocks Technical Data Sheet

PE8227

Description	Connector 1	Connector 2
Type	2.92mm Male	2.92mm Female
Inner Conductor Material and Plating	Beryllium Copper, Gold	Beryllium Copper, Gold
Body Material and Plating	Passivated Stainless Steel	Passivated Stainless Steel

Environmental Specifications

Temperature

Operating Range -65 to +125 deg C

Compliance Certifications (see [product page](#) for current document)

Plotted and Other Data

Notes:

DC Block on Inner and Outer Conductor 2.92mm Male to 2.92mm Female Operating From 10 MHz to 40 GHz from Pasternack Enterprises has same day shipment for domestic and International orders. Our RF, microwave and millimeter wave products maintain a 99% availability and are part of the broadest selection in the industry.

Click the following link (or enter part number in "SEARCH" on website) to obtain additional part information including price, inventory and certifications: [DC Block on Inner and Outer Conductor 2.92mm Male to 2.92mm Female Operating From 10 MHz to 40 GHz PE8227](#)

URL: <https://www.pasternack.com/50-ohm-2.92mm-inner-outer-dc-block-0.1-40-ghz-pe8227-p.aspx>

The information contained in this document is accurate to the best of our knowledge and representative of the part described herein. It may be necessary to make modifications to the part and/or the documentation of the part, in order to implement improvements. Pasternack reserves the right to make such changes as required. Unless otherwise stated, all specifications are nominal. Pasternack does not make any representation or warranty regarding the suitability of the part described herein for any particular purpose, and Pasternack does not assume any liability arising out of the use of any part or documentation.

PE8227 CAD Drawing

DC Block on Inner and Outer Conductor 2.92mm Male to
2.92mm Female Operating From 10 MHz to 40 GHz

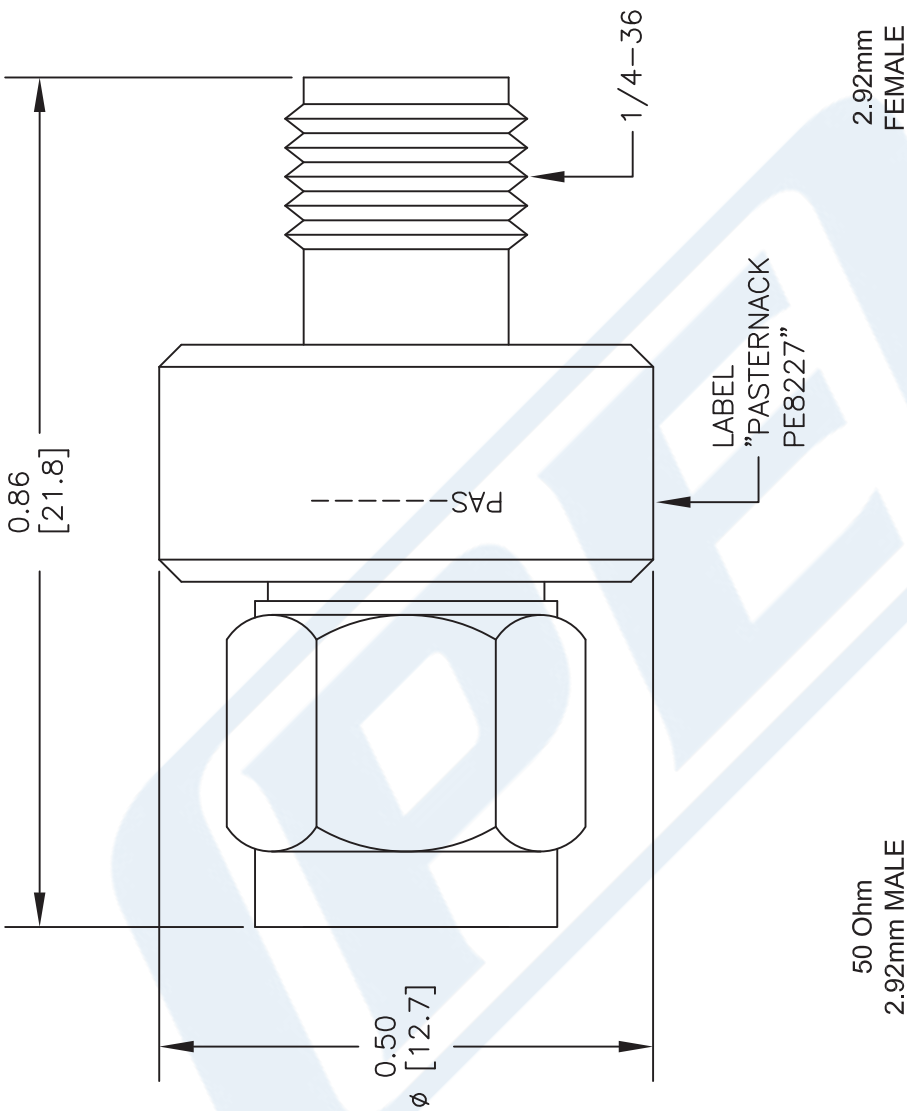

STANDARD TOLERANCES

- .X ±0.2
- .XX ±0.1
- .XXX ±0.05

*STANDARD TOLERANCES APPLY ONLY TO DIMENSIONS IN INCHES



Pasternack Enterprises, Inc.
P.O. Box 16759 | Irvine | CA | 92623
Phone: (949) 261-1920 | Fax: (949) 261-7451
Website: www.pasternack.com | E-Mail: sales@pasternack.com

DWG TITLE

PE8227

FSCM NO. 53919

NOTES:
1. UNLESS OTHERWISE SPECIFIED ALL DIMENSIONS ARE NOMINAL.
2. ALL SPECIFICATIONS ARE SUBJECT TO CHANGE WITHOUT NOTICE AT ANY TIME.
3. DIMENSIONS ARE IN INCHES [mm].

CAD FILE 070816

SCALE N/A

SIZE A

2233