



## High Power 100 Watt RF Load Up to 2.7 GHz With 4.3-10 Male Input Black Anodized Aluminum

### RF Terminations Technical Data Sheet

PE6TR1035

#### Features

- IP67 Indoor/Outdoor Use (Totally dust tight and moisture protected from effects of prolonged immersion under pressure.)
- High Power RF 50 Ohm Impedance
- 698 to 2,700 MHz Frequency Range
- VSWR 1.15:1
- Max Power 100 Watts (CW)
- Low PIM
- 4.3-10 Male Coaxial Interface
- DC Open

#### Applications

- Wireless
- SatCom
- Test and Measurement
- Commercial and Military Communication
- Base Station
- 4G/AWS/PCS

#### Description

Pasternack's PE6TR1035 is a high power RF cable termination (also called RF load or dummy load) that operates from 698 to 2,700 MHz and handles up to 100 Watts (CW). Our 4.3-10 termination / load is a 50 Ohm impedance and has a male gender. PE6TR1035 load termination offers 1.15:1 VSWR and low PIM (passive intermodulation) of 160 dBc. This Pasternack 100 Watts terminator has a heatsink body which is designed to provide adequate heat dissipation within its full frequency of operation.

RF load / terminations are indispensable components in many RF, microwave and millimeter wave systems where signal reflection from unused ports can potentially damage the device or reduce the signal integrity. By terminating an unused port with a matched load (dummy load), the incident energy will be absorbed with minimal reflection. These termination components are commonly used to terminate devices such as couplers, hybrids, and combiners. They are also widely used in measurement systems to ensure accurate results. Pasternack offers a huge selection of RF, microwave and millimeter wave terminations up to 65 GHz with excellent performance over the entire operating range and power handling capabilities up to 800 Watts (CW).

#### Electrical Specifications

Description	Minimum	Typical	Maximum	Units
Frequency Range	0.698		2.7	GHz
Impedance		50		Ohms
VSWR		1.07:1	1.15:1	
Return Loss		30	23	dB
Passive Intermodulation	-160			dBc
Input Power (CW)			100	Watts

#### Mechanical Specifications

##### Size

Length	6.77 in [171.96 mm]
Width	4 in [101.6 mm]
Height	3.19 in [81.03 mm]

Click the following link (or enter part number in "SEARCH" on website) to obtain additional part information including price, inventory and certifications: [High Power 100 Watt RF Load Up to 2.7 GHz With 4.3-10 Male Input Black Anodized Aluminum PE6TR1035](#)



High Power 100 Watt RF Load Up to 2.7 GHz With  
4.3-10 Male Input Black Anodized Aluminum

RF Terminations Technical Data Sheet

PE6TR1035

Weight 5.072 lbs [2.3 Kg]

**Configuration**

Connector 4.3-10 Male

**Material Specifications**

Description	Material	Plating
Housing	Black Anodized Aluminum	

**Compliance Certifications** (visit [www.Pasternack.com](http://www.Pasternack.com) for current document)

RoHS Compliant  
REACH Compliant 12/17/2015

**Plotted and Other Data**

Notes:

**Typical Performance Data**

**Passive Intermodulation Test Data**

Tone 1 Frequency (MHz)	Tone 2 Frequency (MHz)	IM3 Frequency (MHz)	PIM Minimum (dBc)
1945.0	1990.0	1900.0	-160.0
P1	P2	PIM	Result
43.0 dBm	43.0 dBm	-173.1 dBc	Pass

Click the following link (or enter part number in "SEARCH" on website) to obtain additional part information including price, inventory and certifications: [High Power 100 Watt RF Load Up to 2.7 GHz With 4.3-10 Male Input Black Anodized Aluminum PE6TR1035](#)



## High Power 100 Watt RF Load Up to 2.7 GHz With 4.3-10 Male Input Black Anodized Aluminum

### RF Terminations Technical Data Sheet

PE6TR1035

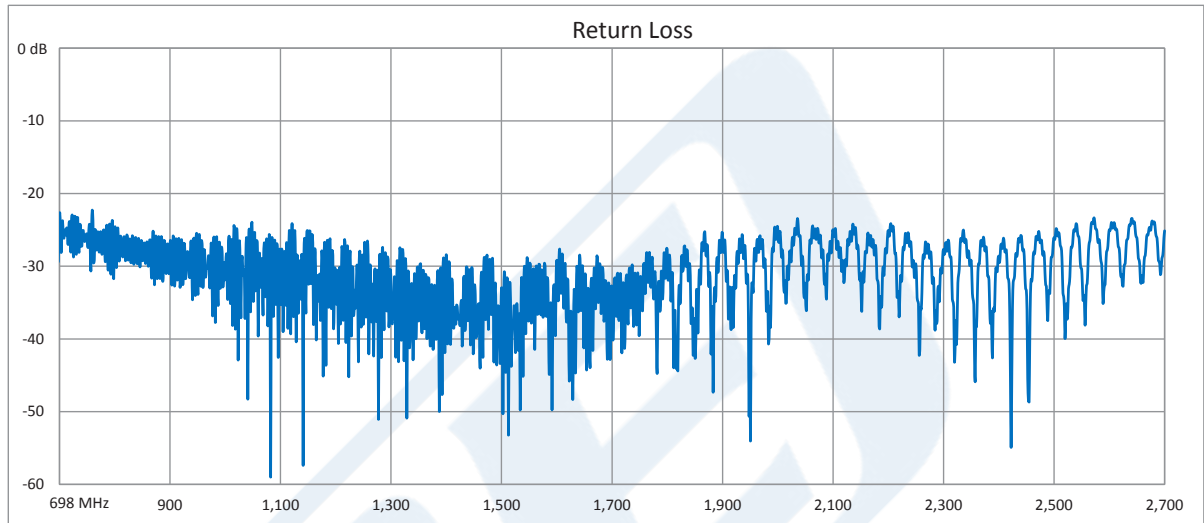

High Power 100 Watt RF Load Up to 2.7 GHz With 4.3-10 Male Input Black Anodized Aluminum from Pasternack Enterprises has same day shipment for domestic and International orders. Our RF, microwave and millimeter wave products maintain a 99% availability and are part of the broadest selection in the industry.

Click the following link (or enter part number in "SEARCH" on website) to obtain additional part information including price, inventory and certifications: [High Power 100 Watt RF Load Up to 2.7 GHz With 4.3-10 Male Input Black Anodized Aluminum PE6TR1035](#)

URL: <https://www.pasternack.com/100-watts-4.3-10-male-rf-load-up-to-2.7-ghz-low-pim-pe6tr1035-p.aspx>

The information contained in this document is accurate to the best of our knowledge and representative of the part described herein. It may be necessary to make modifications to the part and/or the documentation of the part, in order to implement improvements. Pasternack reserves the right to make such changes as required. Unless otherwise stated, all specifications are nominal. Pasternack does not make any representation or warranty regarding the suitability of the part described herein for any particular purpose, and Pasternack does not assume any liability arising out of the use of any part or documentation.

# PE6TR1035 CAD Drawing

High Power 100 Watt RF Load Up to 2.7 GHz With  
4.3-10 Male Input Black Anodized Aluminum

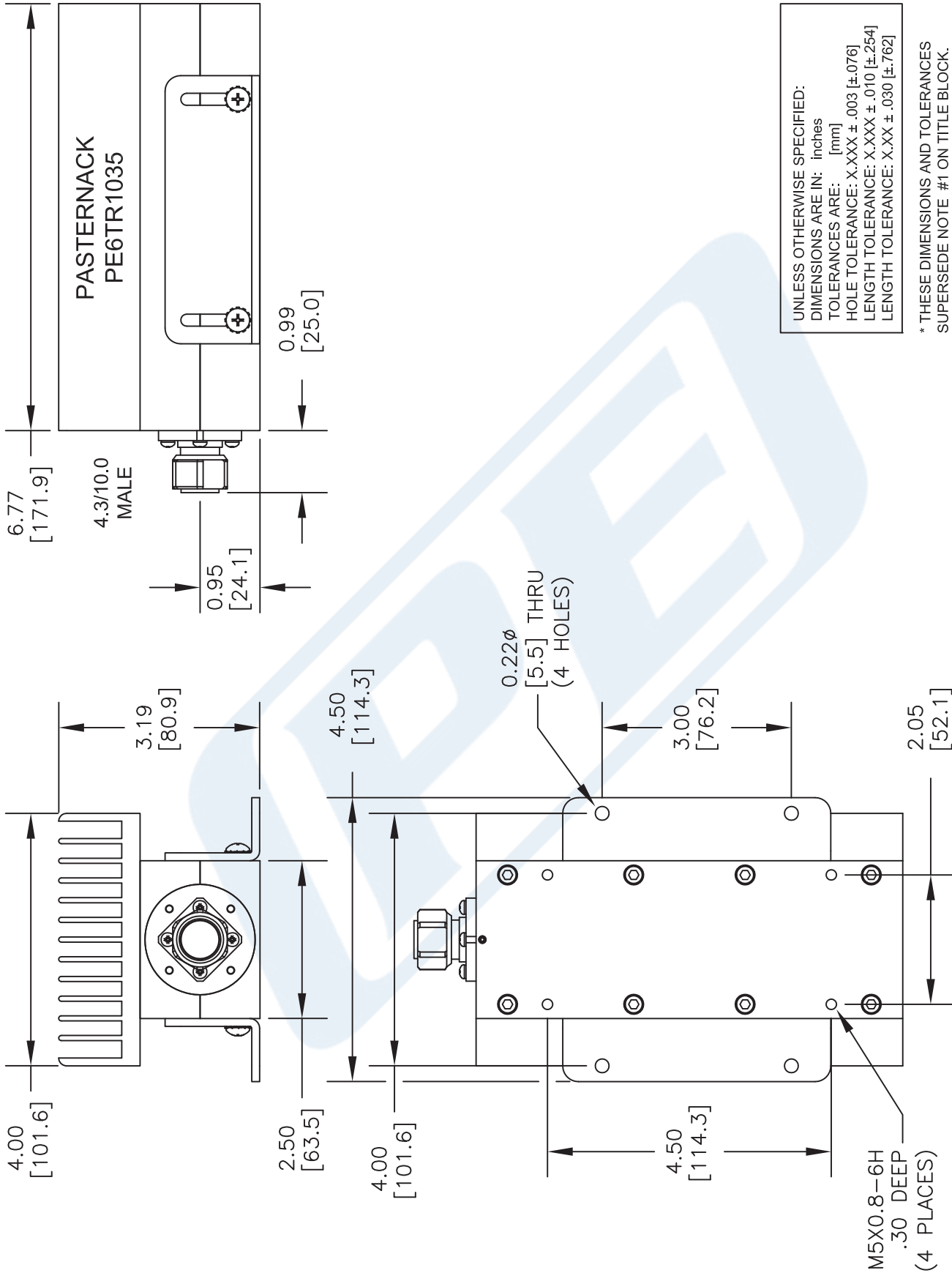

UNLESS OTHERWISE SPECIFIED:  
DIMENSIONS ARE IN: inches  
TOLERANCES ARE: [mm]  
HOLE TOLERANCE: X.XXX  $\pm$  .003 [ $\pm$ .076]  
LENGTH TOLERANCE: X.XXX  $\pm$  .010 [ $\pm$ .254]  
LENGTH TOLERANCE: X.XX  $\pm$  .030 [ $\pm$ .762]

\* THESE DIMENSIONS AND TOLERANCES  
SUPERSEDE NOTE #1 ON TITLE BLOCK.

**NOTES:**

1. UNLESS OTHERWISE SPECIFIED ALL DIMENSIONS ARE NOMINAL.
2. ALL SPECIFICATIONS ARE SUBJECT TO CHANGE WITHOUT NOTICE AT ANY TIME.
3. DIMENSIONS ARE IN INCHES [mm].

**DWG TITLE**

**PE6TR1035**



Pasternack Enterprises, Inc.  
P.O. Box 16759 | Irvine | CA | 92623  
Phone: (949) 261-1920 | Fax: (949) 261-7451  
Website: www.pasternack.com | E-Mail: sales@pasternack.com

**FSCM NO. 53919**

CAD FILE 053116

SCALE N/A

SIZE A

2233