



75 Ohm BNC Male Right Angle Connector Crimp/ Solder Attachment for RG179, RG187

RF Connectors Technical Data Sheet

PE4610

Configuration

- BNC Male Connector
- 75 Ohms
- Right Angle Body Geometry
- Connector Interface Types: RG179, RG187

Features

- Max. Operating Frequency 500 MHz
- Good VSWR of 1.3:1
- Gold Plated Brass Contact
- 30 µm minimum contact plating

Applications

- General Purpose Test
- Custom Cable Assemblies
- CATV

Description

Pasternack's PE4610 75 ohm BNC male right angle connector with crimp/solder attachment for RG179 and RG187 is part of our full line of RF components available for same-day shipping. Our BNC male connector operates up to a maximum frequency of 500 MHz and offers good VSWR of 1.3:1. Its right angle body geometry allows for easier connections in tight spaces.

Our 75 ohm BNC male right angle connector PE4610 datasheet specifications and drawing with dimensions are shown below in this PDF. Pasternack's broad catalog of RF, microwave and millimeter wave connectors allows designers to configure and customize their signal connections however they like. Whether the need is to provide an I/O for a board design, or simply create a custom cable assembly configuration, Pasternack has the right connector for the job. Pasternack can also expertly build your custom cable assemblies for you and ship same-day.

Electrical Specifications

Description	Minimum	Typical	Maximum	Units
Frequency Range	DC		500	MHz
VSWR			1.3:1	
Operating Voltage (AC)			500	Vrms

Mechanical Specifications

Size	
Length	1.064 in [27.03 mm]
Width/Dia.	0.57 in [14.48 mm]
Height	1.748 in [44.4 mm]
Weight	0.061 lbs [27.67 g]

Click the following link (or enter part number in "SEARCH" on website) to obtain additional part information including price, inventory and certifications: [75 Ohm BNC Male Right Angle Connector Crimp/Solder Attachment for RG179, RG187 PE4610](#)



75 Ohm BNC Male Right Angle Connector Crimp/ Solder Attachment for RG179, RG187

RF Connectors Technical Data Sheet

PE4610

Material Specifications

Description	Material	Plating
Contact	Brass	Gold 30 µin minimum
Insulation	PTFE	
Body	Brass	Nickel 100 µin minimum
Coupling Nut	Brass	Nickel 100 µin minimum

Environmental Specifications

Temperature

Operating Range

-65 to +165 deg C

Compliance Certifications (see [product page](#) for current document)

Plotted and Other Data

Notes:

75 Ohm BNC Male Right Angle Connector Crimp/Solder Attachment for RG179, RG187 from Pasternack Enterprises has same day shipment for domestic and International orders. Our RF, microwave and millimeter wave products maintain a 99.4% availability and are part of the broadest selection in the industry.

Click the following link (or enter part number in "SEARCH" on website) to obtain additional part information including price, inventory and certifications: [75 Ohm BNC Male Right Angle Connector Crimp/Solder Attachment for RG179, RG187 PE4610](#)

URL: <https://www.pasternack.com/bnc-male-standard-rg179-rg187-connector-pe4610-p.aspx>

The information contained in this document is accurate to the best of our knowledge and representative of the part described herein. It may be necessary to make modifications to the part and/or the documentation of the part, in order to implement improvements. Pasternack reserves the right to make such changes as required. Unless otherwise stated, all specifications are nominal. Pasternack does not make any representation or warranty regarding the suitability of the part described herein for any particular purpose, and Pasternack does not assume any liability arising out of the use of any part or documentation.

PE4610 CAD Drawing

75 Ohm BNC Male Right Angle Connector Crimp/Solder Attachment for RG179, RG187

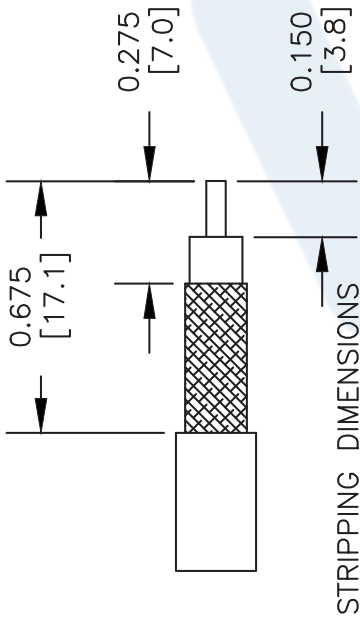
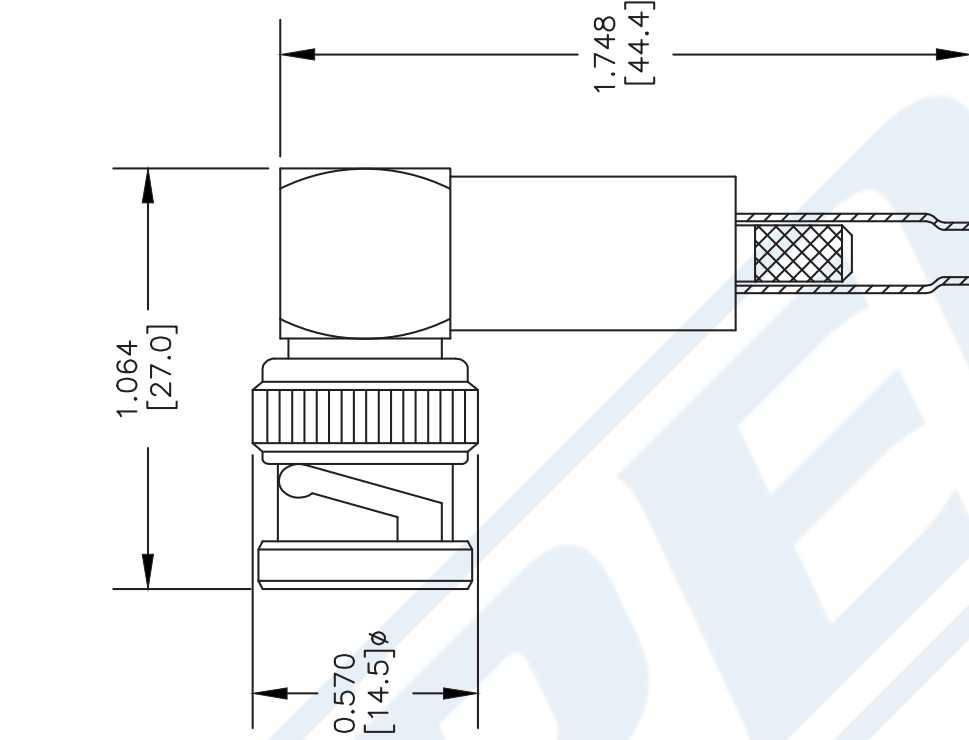

STRIPPING DIMENSIONS

ASSEMBLY PROCEDURES

1. STRIP CABLE AS SHOWN & SLIDE FERRULE (1) ONTO CABLE.
2. FLARE END OF CABLE BRAID & SLIDE METAL SPACER (2) & PTFE (3) SPACER OVER CABLE DIELECTRIC
3. THE CONTACT (4) SHOULD BUTT . AGAINST THE DIELECTRIC & PTFE SPACER. CRIMP CONTACT TO CABLE CENTER CONDUCTOR
4. INSTALL CABLE ASSEMBLY INTO BODY SO THAT THE INNER FERRULE PORTION OF BODY SLIDES UNDER BRAID. PUSH CABLE ASSEMBLY FORWARD UNTIL CONTACT SNAPS INTO PLACE. SLIDE FERRULE OVER BRAID AND UP AGAINST CONNECTOR BODY & CRIMP.

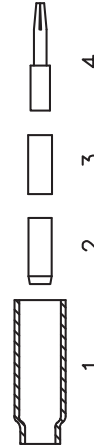

CRIMP SIZE REQUIRED

CONTACT: .068" HEX CRIMP TOOL
 FERRULE: .178" HEX CRIMP TOOL



Pasternack Enterprises, Inc.
 P.O. Box 16759 | Irvine | CA | 92623
 Phone: (949) 261-1920 | Fax: (949) 261-7451
 Website: www.pasternack.com | E-Mail: sales@pasternack.com

DWG TITLE

PE4610

FSCM NO. 53919

NOTES:
 1. UNLESS OTHERWISE SPECIFIED ALL DIMENSIONS ARE NOMINAL.
 2. ALL SPECIFICATIONS ARE SUBJECT TO CHANGE WITHOUT NOTICE AT ANY TIME.
 3. DIMENSIONS ARE IN INCHES [mm].
 4. FITS MIL-C-17 AND EQUIVALENT CABLES.

CAD FILE 052402

SCALE N/A

SIZE A

XXXX