



75 Ohm F Male Connector Crimp/Solder Attachment for RG179, RG187

RF Connectors Technical Data Sheet

PE45520

Configuration

- F Male Connector
- 75 Ohms
- Straight Body Geometry
- Connector Interface Types: RG179, RG187
- 7/16 inch Hex

Features

- Max. Operating Frequency 1 GHz
- Good VSWR of 1.35:1
- Gold Plated Brass Contact

Applications

- General Purpose Test
- Custom Cable Assemblies
- CATV

Description

Pasternack's PE45520 75 ohm type F male connector with crimp/solder attachment for RG179 and RG187 is part of our full line of RF components available for same-day shipping. Our type F male connector operates up to a maximum frequency of 1 GHz and offers good VSWR of 1.35:1.

Our 75 ohm type F male connector PE45520 datasheet specifications and drawing with dimensions are shown below in this PDF. Pasternack's broad catalog of RF, microwave and millimeter wave connectors allows designers to configure and customize their signal connections however they like. Whether the need is to provide an I/O for a board design, or simply create a custom cable assembly configuration, Pasternack has the right connector for the job. Pasternack can also expertly build your custom cable assemblies for you and ship same-day.

Electrical Specifications

Description	Minimum	Typical	Maximum	Units
Frequency Range	DC		1,000	MHz
VSWR			1.35:1	
Operating Voltage (AC)			500	Vrms

Mechanical Specifications

Size

Length	0.845 in [21.46 mm]
Width/Dia.	0.433 in [11.00 mm]
Weight	0.01 lbs [4.54 g]
Mating Torque	12 to 15 in-lbs [1.36 to 1.70 Nm]

Click the following link (or enter part number in "SEARCH" on website) to obtain additional part information including price, inventory and certifications: [75 Ohm F Male Connector Crimp/Solder Attachment for RG179, RG187 PE45520](#)



75 Ohm F Male Connector Crimp/Solder
Attachment for RG179, RG187

RF Connectors
Technical Data Sheet

PE45520

Material Specifications

Description	Material	Plating
Contact	Brass	Gold
Insulation	PTFE	
Body	Brass	Nickel
Coupling Nut	Brass	Nickel

Environmental Specifications

Compliance Certifications (see [product page](#) for current document)

Plotted and Other Data

Notes:

75 Ohm F Male Connector Crimp/Solder Attachment for RG179, RG187 from Pasternack Enterprises has same day shipment for domestic and International orders. Our RF, microwave and millimeter wave products maintain a 99.4% availability and are part of the broadest selection in the industry.

Click the following link (or enter part number in "SEARCH" on website) to obtain additional part information including price, inventory and certifications: [75 Ohm F Male Connector Crimp/Solder Attachment for RG179, RG187 PE45520](#)

URL: <https://www.pasternack.com/f-male-rg179-rg187-connector-pe45520-p.aspx>

The information contained in this document is accurate to the best of our knowledge and representative of the part described herein. It may be necessary to make modifications to the part and/or the documentation of the part, in order to implement improvements. Pasternack reserves the right to make such changes as required. Unless otherwise stated, all specifications are nominal. Pasternack does not make any representation or warranty regarding the suitability of the part described herein for any particular purpose, and Pasternack does not assume any liability arising out of the use of any part or documentation.

PE45520 CAD Drawing

75 Ohm F Male Connector Crimp/Solder Attachment for RG179, RG187

REVISIONS			
REV.	DESCRIPTION	DATE	APPROVED
A	INITIAL RELEASE	08/05/19	S.ELLIS

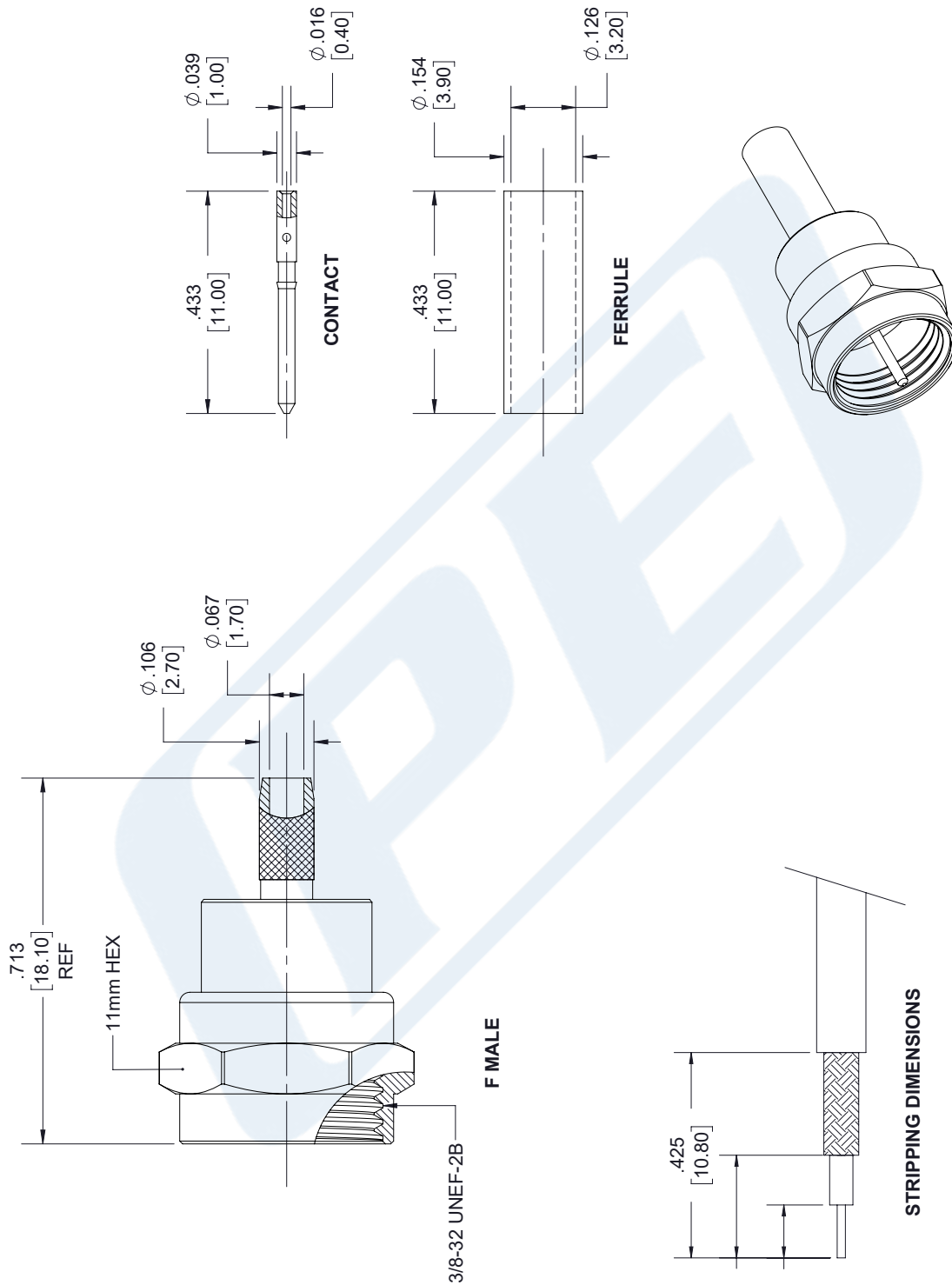

NOTES:

- CABLE ATTACHMENT:
 - OUTER: CRIMP.
 - INNER: SOLDER.
- CRIMP SIZE REQUIRED:
 - FERRULE: .128 [3.25] HEX. CRIMP TOOL.
 - CONTACT: SOLDER.

UNLESS OTHERWISE SPECIFIED
LEADING DIMENSIONS ARE INCHES
DIMENSIONS IN [] ARE MILLIMETERS

TOLERANCES:

X±.2	[5.08]	FRACTIONS
.XX±.01	[.25]	±132
.XXX±.005	[.13]	ANGLES ± 1°

ALL DIMENSIONS SHOWN
ARE FOR REFERENCE ONLY.

THIRD-ANGLE PROJECTION

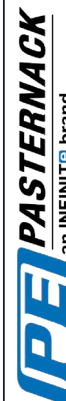

PASTERNAK
an INFINITO brand

Pasternack Enterprises, Inc.
P.O. Box 16759, Irvine, CA 92623.
Phone: 1.949.261.1920 | 1.866.727.8376
Fax: 1.949.261.7451
www.pasternack.com | e-mail: sales@pasternack.com

SIZE	CAGE	DRAWN BY	PART NUMBER
A	53919	K.DANG	PE45520

THE INFORMATION AND DESIGN IN THIS DOCUMENT IS THE PROPERTY OF PASTERNAK CORPORATION. ALL RIGHTS RESERVED.			
SHEET	1	OF	1
SCALE	N/A		
REV	A		

THESE COMMODITIES, TECHNOLOGY OR SOFTWARE WERE EXPORTED FROM THE UNITED STATES IN ACCORDANCE WITH THE EXPORT ADMINISTRATION REGULATIONS. DIVERSION CONTRARY TO U.S. LAW PROHIBITED.