

MATERIALS

BODY	BRASS NICKEL PLATED
CONTACT	GOLD PLATED
INSULATOR	PTFE

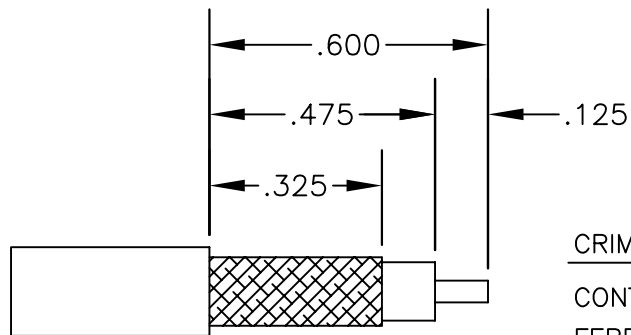
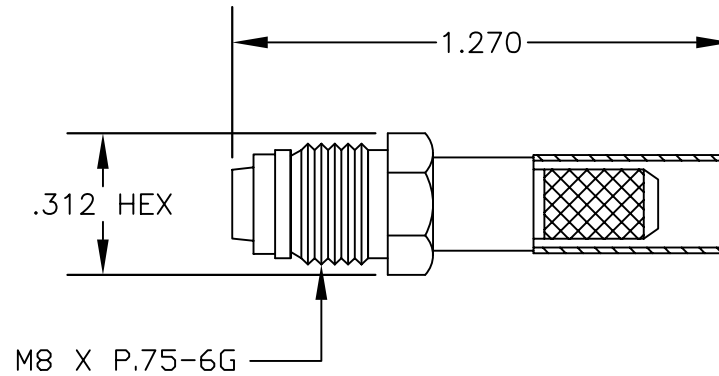

STRIPPING DIMENSIONS

CRIMP SIZES REQUIRED

CONTACT: .068" HEX CRIMP TOOL
 FERRULE: .213" HEX CRIMP TOOL



PASTERNACK ENTERPRISES, INC.

P.O BOX 16759, IRVINE, CA 92623
 PHONE (949) 261-1920 FAX (949) 261-7451

WEB ADDRESS: www.pasternack.com
 E-MAIL ADDRESS: sales@pasternack.com

COAXIAL & FIBER OPTICS

DWG TITLE

PE44147

DES.

FME JACK, CRIMP ATTACHMENT FOR RG55,
 RG142, RG223 & RG400

SIZE A

FSCM NO. 53919

CAD FILE

062702

SCALE N/A

127

NOTES:

1. UNLESS OTHERWISE SPECIFIED ALL DIMENSIONS ARE NOMINAL.
2. ALL SPECIFICATIONS ARE SUBJECT TO CHANGE WITHOUT NOTICE AT ANY TIME.