

**MATERIALS**

<b>BODY</b>	<b>BRASS NICKEL PLATED</b>
<b>CONTACT</b>	<b>GOLD PLATED</b>
<b>INSULATOR</b>	<b>PTFE</b>

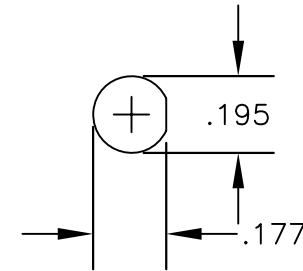

MOUNTING HOLE

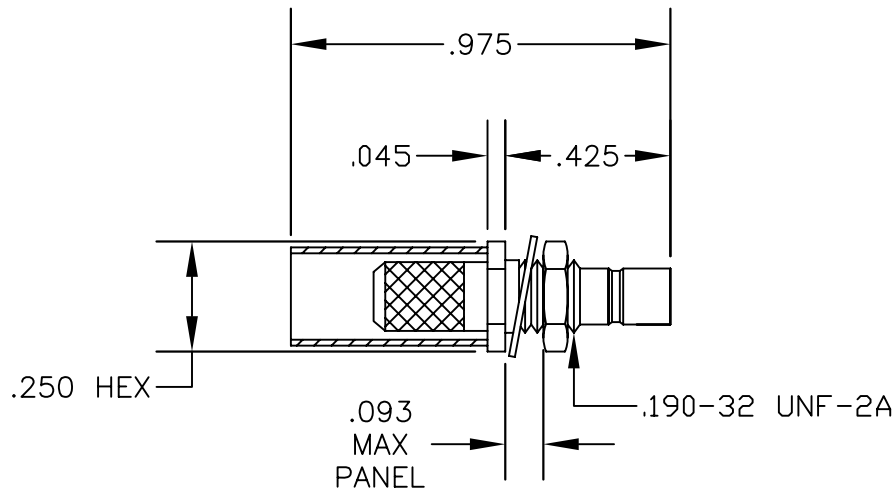
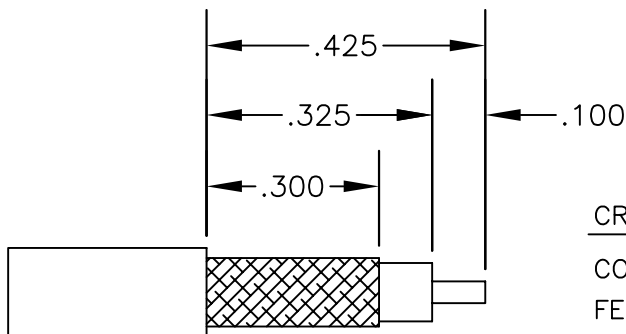

STRIPPING DIMENSIONS

CRIMP SIZE REQUIRED

CONTACT: SOLDER

FERRULE: .213" HEX CRIMP TOOL



**PASTERNAK ENTERPRISES, INC.**

P.O BOX 16759, IRVINE, CA 92623  
 PHONE (949) 261-1920 FAX (949) 261-7451

WEB ADDRESS: [www.pasternack.com](http://www.pasternack.com)  
 E-MAIL ADDRESS: [sales@pasternack.com](mailto:sales@pasternack.com)

**COAXIAL & FIBER OPTICS**

DWG TITLE

**PE44094**

DES.

SMB JACK, BULKHEAD CRIMP ATTACHMENT FOR RG58

SIZE A

**FSCM NO. 53919**

CAD FILE

062502

SCALE N/A

127

**NOTES:**

1. UNLESS OTHERWISE SPECIFIED ALL DIMENSIONS ARE NOMINAL.
2. ALL SPECIFICATIONS ARE SUBJECT TO CHANGE WITHOUT NOTICE AT ANY TIME.