



N Female to SMA Male Low PIM Cable Using 1/4 inch Superflexible Coax in 24 Inch

RF Cable Assemblies Technical Data Sheet

PE3W14156-24

Configuration

- Connector 1: N Female
- Connector 2: SMA Male
- Cable Type: 1/4" Superflexible

Features

- Max Frequency 3 GHz
- Shielding Effectivity > 120 dB
- 82% Phase Velocity
- PE Jacket

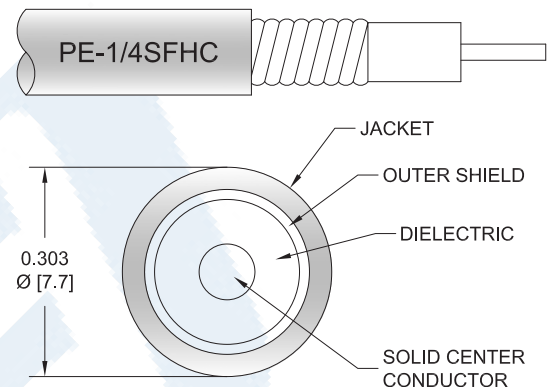

Applications

- General Purpose
- Laboratory Use
- Low PIM Applications

Description

Pasternack's PE3W14156-24 type N female to SMA male 24 inch cable using 1/4 inch superflexible coax is part of our full line of RF components available for same-day shipping. Pasternack's corrugated RF cable assemblies are ideal for applications where durability and high power are needed. This Pasternack type N to SMA cable assembly has a female to male gender configuration with 50 ohm corrugated 1/4" superflexible coax. The PE3W14156-24 type N female to SMA male cable assembly operates to 3 GHz. Our low PIM design also offers excellent passive intermodulation performance.

Custom versions of most RF cable assemblies can be built and shipped same day. Custom cable assembly lengths can be obtained by specifying the desired length on the web site at time of order or by contacting a sales representative. Other available RF cable assembly value added services include connector orientation or clocking, heat shrink booting and custom labeling. RF testing can also be performed to document the electrical performance of your cable assembly.

Click the following link (or enter part number in "SEARCH" on website) to obtain additional part information including price, inventory and certifications: [N Female to SMA Male Low PIM Cable Using 1/4 inch Superflexible Coax in 24 Inch PE3W14156-24](#)



N Female to SMA Male Low PIM Cable Using 1/4 inch Superflexible Coax in 24 Inch

RF Cable Assemblies Technical Data Sheet

PE3W14156-24

Electrical Specifications

Description	Minimum	Typical	Maximum	Units
Frequency Range	DC		3	GHz
VSWR			1.5:1	
Velocity of Propagation		82		%
RF Shielding	120			dB
Capacitance		24.4 [80.05]		pF/ft [pF/m]
Inductance		0.059 [0.19]		uH/ft [uH/m]
DC Resistance Inner Conductor		3.2 [10.5]		Ω /1000ft [Ω /Km]
DC Resistance Outer Conductor		2.53 [8.3]		Ω /1000ft [Ω /Km]
Jacket Spark			2,000	Vrms

Specifications by Frequency

Description	F1	F2	F3	F4	F5	Units
Frequency	0.1	0.25	0.5	1	3	GHz
Insertion Loss (Typ.)	0.24	0.26	0.28	0.32	0.42	dB

Electrical Specification Notes:

The Insertion Loss data above is based on the performance specifications of the coax and connectors used in this assembly. The Insertion Loss includes an estimated insertion loss of 0.1 dB per connector.

Mechanical Specifications

Cable Assembly

Length*	24 in [609.6 mm]
Weight	0.232 lbs [105.23 g]

Cable

Cable Type	1/4" Superflexible
Impedance	50 Ohms
Inner Conductor Type	Solid
Inner Conductor Material and Plating	Copper Clad Aluminum
Dielectric Type	PE (F)
Number of Shields	1
Shield Layer 1	Helically Corrugated Copper Tube
Jacket Material	PE, Black
Jacket Diameter	0.303 in [7.7 mm]

One Time Minimum Bend Radius	0.5 in [12.7 mm]
Repeated Minimum Bend Radius	1 in [25.4 mm]

Click the following link (or enter part number in "SEARCH" on website) to obtain additional part information including price, inventory and certifications: [N Female to SMA Male Low PIM Cable Using 1/4 inch Superflexible Coax in 24 Inch PE3W14156-24](#)



N Female to SMA Male Low PIM Cable Using
1/4 inch Superflexible Coax in 24 Inch

RF Cable Assemblies Technical Data Sheet

PE3W14156-24

Typical Flex Cycles 20
Tensile Strength 79 lbs [35.83 Kg]

Connectors

Description	Connector 1	Connector 2
Type	N Female	SMA Male
Specification	IEC 60169-16	
Impedance	50 Ohms	50 Ohms
Mating Cycles	500	
Contact Material and Plating	Spring Copper, Silver	Brass, Silver
Contact Plating Specification	5 µm minimum	
Dielectric Type	PTFE	PTFE
Outer Conductor Material and Plating	Brass, Nickel	
Outer Conductor Plating Specification	5 µm minimum	
Body Material and Plating	Brass, Tri-Metal	Brass, Tri-Metal
Body Plating Specification	2 µm minimum	
Coupling Nut Material and Plating		Brass, Tri-Metal

Environmental Specifications

Temperature

Operating Range -40 to +85 deg C

Compliance Certifications (see [product page](#) for current document)

Plotted and Other Data

Notes:

Click the following link (or enter part number in "SEARCH" on website) to obtain additional part information including price, inventory and certifications: [N Female to SMA Male Low PIM Cable Using 1/4 inch Superflexible Coax in 24 Inch PE3W14156-24](#)



N Female to SMA Male Low PIM Cable Using
1/4 inch Superflexible Coax in 24 Inch

RF Cable Assemblies Technical Data Sheet

PE3W14156-24

How to Order

Part Number Configuration:

PE3W14156

- **xx**

uu

Unit of Measure:
cm = Centimeters
<blank> = Inches
Length
Base Number

Example: PE3W14156-12 = 12 inches long cable
PE3W14156-100cm = 100 cm long cable

N Female to SMA Male Low PIM Cable Using 1/4 inch Superflexible Coax in 24 Inch from Pasternack Enterprises has same day shipment for domestic and International orders. Our RF, microwave and millimeter wave products maintain a 99.4% availability and are part of the broadest selection in the industry.

Click the following link (or enter part number in "SEARCH" on website) to obtain additional part information including price, inventory and certifications: [N Female to SMA Male Low PIM Cable Using 1/4 inch Superflexible Coax in 24 Inch PE3W14156-24](https://www.pasternack.com/n-female-to-sma-male-low-pim-cable-using-1-4-inch-superflexible-pe3w14156-24-p.aspx)

URL: <https://www.pasternack.com/n-female-to-sma-male-low-pim-cable-using-1-4-inch-superflexible-pe3w14156-24-p.aspx>

The information contained in this document is accurate to the best of our knowledge and representative of the part described herein. It may be necessary to make modifications to the part and/or the documentation of the part, in order to implement improvements. Pasternack reserves the right to make such changes as required. Unless otherwise stated, all specifications are nominal. Pasternack does not make any representation or warranty regarding the suitability of the part described herein for any particular purpose, and Pasternack does not assume any liability arising out of the use of any part or documentation.

PE3W14156-24 CAD Drawing

N Female to SMA Male Low PIM Cable Using 1/4 inch Superflexible Coax in 24 Inch

REVISIONS			
REV.	DESCRIPTION	DATE	APPROVED
A	INITIAL RELEASE	08/10/2022	AGANWANI

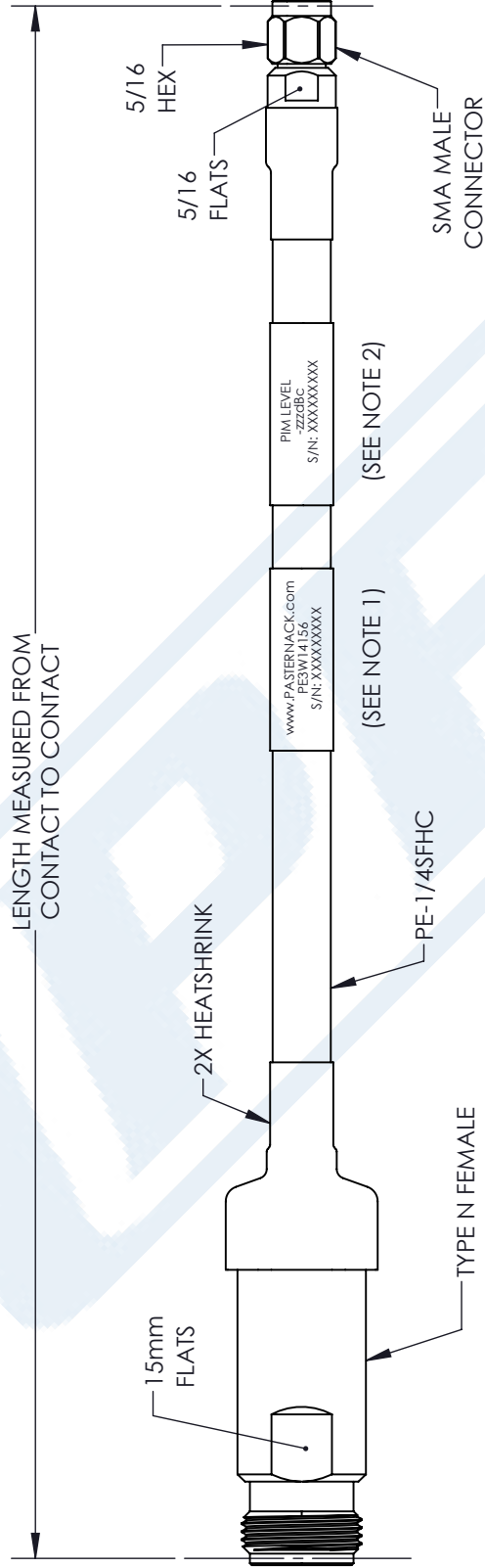

<p>PE PASTERNAK an INFINITI[®] brand</p> <p>Pasternack Enterprises, Inc. P. O. Box 16759, Irvine, CA 92623. Phone: 1.949.261.1920 1.866.727.8376 Fax: 1.949.261.7451 Website: www.pasternack.com E-mail: sales@pasternack.com</p>	<p>THIRD-ANGLE PROJECTION</p> <p>THE INFORMATION AND DESIGN IN THIS DOCUMENT IS THE PROPERTY OF PASTERNAK CORPORATION ALL RIGHTS RESERVED.</p> <p>SHEET 1 OF 1</p>
	<p>SCALE N/A</p>
<p>UNLESS OTHERWISE SPECIFIED LEADING DIMENSIONS ARE INCHES DIMENSIONS IN [] ARE MILLIMETERS</p> <p>TOLERANCES:</p> <p>.X = ±.2 [.008] FRACTIONS .XX = ±.02 [.51] ±.1/32 .XXX = ±.005 [.13] ANGLES ± 1°</p> <p>CABLE LENGTH (L) TOLERANCES: L ≤ 12 [305] = +1 [25] / -0 12 [305] < L ≤ 60 [1524] = +2 [51] / -0 60 [1524] < L ≤ 120 [3048] = +4 [102] / -0 120 [3048] < L ≤ 300 [7620] = +6 [152] / -0 300 [7620] < L = +5% / -0</p> <p>ALL DIMENSIONS SHOWN ARE FOR REFERENCE ONLY.</p>	<p>SIZE A</p> <p>CAGE CODE 53919</p> <p>DRAWN BY BPUCHASKI</p> <p>ITEM NO. PE3W14156</p> <p>REV A</p>

- NOTES:
- CABLES 84" AND UNDER HAVE 1 LABEL CENTERED. CABLES OVER 84" HAVE 2 LABELS, ONE AT EACH END 12.0" FROM END OF CONNECTOR.
 - 6" FROM CABLE END, 1 PLACE, FOR ALL LENGTHS OF CABLE.
- THESE COMMODITIES, TECHNOLOGY OR SOFTWARE WERE EXPORTED FROM THE UNITED STATES IN ACCORDANCE WITH THE EXPORT ADMINISTRATION REGULATIONS. DIVERSION CONTRARY TO U.S. LAW PROHIBITED.