

SMA Female Bulkhead to Push-On SMP  
Female Right Angle Low Loss Cable Using  
LMR-100 Coax with 90 Deg. Clock in 24 Inch



**PE3W07349/PH90-24**

**Configuration**

- Connector 1: SMA Female Bulkhead
- Connector 2: Push-On SMP Female Right Angle
- Cable Type: LMR-100A
- Coax Flex Type: Flexible

**Features**

- Shielding Effectivity > 90 dB
- 66% Phase Velocity
- Double Shielded
- PVC Jacket

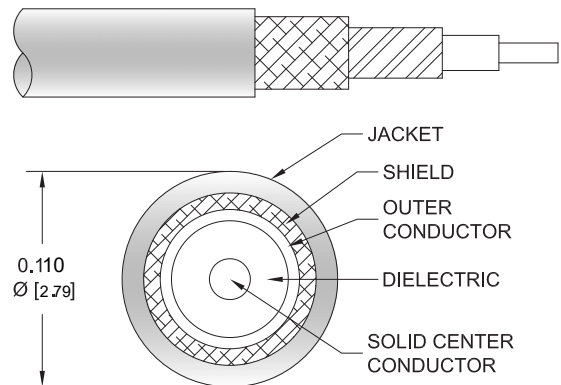

**Applications**

- General Purpose
- Laboratory Use

**Description**

Pasternack's PE3W07349/PH90-24 SMA female bulkhead to SMP female push-on right angle 24 inch cable using LMR-100 coax is part of our full line of RF components available for same-day shipping. Pasternack's flexible RF cable assemblies are ideal for applications where tight bends and flexure are required. This Pasternack SMA to SMP cable assembly has a female to female gender configuration with 50 ohm flexible LMR-100A coax. The right angle SMP interface on the LMR-100A cable allows for easier connections in tight spaces. Our RF cable assembly with SMA bulkhead interface allows designers to create external connections on their product enclosures, and can be used in a variety of other rack mount and panel mount applications. The double shielding of this Pasternack cable assembly provides excellent shielding effectiveness of better than 90 dB.

Custom versions of most RF cable assemblies can be built and shipped same day. Custom cable assembly lengths can be obtained by specifying the desired length on the web site at time of order or by contacting a sales representative. Other available RF cable assembly value added services include connector orientation or clocking, heat shrink booting and custom labeling. RF testing can also be performed to document the electrical performance of your cable assembly.

**Electrical Specifications**

Description	Minimum	Typical	Maximum	Units
Velocity of Propagation		66		%
RF Shielding	90			dB
Group Delay		1.54 [5.05]		ns/ft [ns/m]
Capacitance		30.8 [101.05]		pF/ft [pF/m]
Inductance		0.077 [0.25]		uH/ft [uH/m]
DC Resistance Inner Conductor		81 [265.75]		Ohms/1000ft [Ohms/Km]
DC Resistance Outer Conductor		9.5 [31.17]		Ohms/1000ft [Ohms/Km]

SMA Female Bulkhead to Push-On SMP  
Female Right Angle Low Loss Cable Using  
LMR-100 Coax with 90 Deg. Clock in 24 Inch



**PE3W07349/PH90-24**

**Electrical Specifications**

Description	Minimum	Typical	Maximum	Units
Jacket Spark			2,000	Vrms

**Mechanical Specifications**

**Cable Assembly**

Length	24 in [609.6 mm]
Width/Diameter	0.5 in [12.7 mm]
Weight	0.026 lbs [11.79 g]

**Cable**

Cable Type	LMR-100A
Impedance	50 Ohms
Inner Conductor Type	Solid
Inner Conductor Material and Plating	Copper Clad Steel
Dielectric Type	PE
Number of Shields	2
Shield Layer 1	Aluminum Tape
Shield Layer 2	Tinned Copper Braid
Jacket Material	PVC, Black
Jacket Diameter	0.11 in [2.79 mm]
One Time Minimum Bend Radius	0.25 in [6.35 mm]
Repeated Minimum Bend Radius	1 in [25.4 mm]
Bending Moment	0.1 lbs-ft [0.14 N-m]
Flat Plate Crush	10 lbs/in [0.18 Kg/mm]
Tensile Strength	15 lbs [6.8 Kg]

**Connectors**

Description	Connector 1	Connector 2
Type	SMA Female Bulkhead	SMP Female Right Angle
Specification	MIL-STD-348	MIL-STD-348A
Impedance	50 Ohms	50 Ohms
Configuration	Straight	Right Angle
Connection Method		Push-On
Contact Material and Plating	Beryllium Copper, Gold	Beryllium Copper, Gold
Contact Plating Specification	MIL-G-45204	30μ in. minimum
Dielectric Type		Teflon
Outer Conductor Material and Plating	Brass, Nickel	Beryllium Copper, Gold
Outer Conductor Plating Specification		3μ in. minimum
Body Material and Plating	Brass, Nickel	Brass, Gold
Body Plating Specification		3μ in. minimum

SMA Female Bulkhead to Push-On SMP  
Female Right Angle Low Loss Cable Using  
LMR-100 Coax with 90 Deg. Clock in 24 Inch



**PE3W07349/PH90-24**

**Environmental Specifications**

**Compliance Certifications** (see [product page](#) for current document)

**Plotted and Other Data**

Notes:

**Typical Performance Data**

**How to Order**

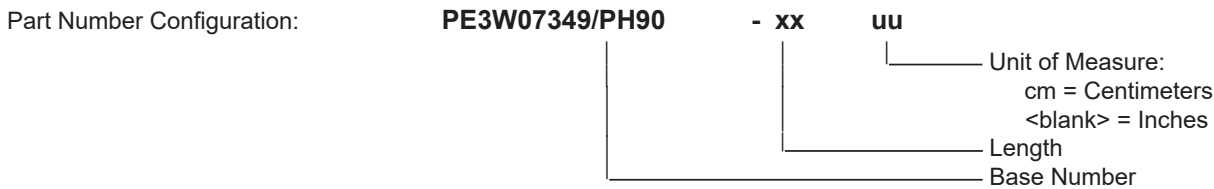

Example: PE3W07349/PH90-12 = 12 inches long cable  
PE3W07349/PH90-100cm = 100 cm long cable

SMA Female Bulkhead to Push-On SMP Female Right Angle Low Loss Cable Using LMR-100 Coax with 90 Deg. Clock in 24 Inch from Pasternack Enterprises has same day shipment for domestic and International orders. Our RF, microwave and millimeter wave products maintain a 99.4% availability and are part of the broadest selection in the industry.

Click the following link (or enter part number in "SEARCH" on website) to obtain additional part information including price, inventory and certifications: [SMA Female Bulkhead to Push-On SMP Female Right Angle Low Loss Cable Using LMR-100 Coax with 90 Deg. Clock in 24 Inch PE3W07349/PH90-24](#)

URL: <https://www.pasternack.com/sma-female-bulkhead-to-push-on-smp-female-cable-using-lmr-100-with-90-deg.-clock-pe3w07349-ph90-24-p.aspx>

The information contained within this document is accurate to the best of our knowledge and representative of the part described herein. It may be necessary to make modifications to the part and/or the documentation of the part in order to implement improvements. Pasternack Enterprises reserves the right to make such changes as required. Unless otherwise stated, all specifications are nominal. Pasternack Enterprises does not make any representation or warranty regarding the suitability of the part described herein for any particular purpose, and Pasternack Enterprises does not assume liability arising out of the use of any part or document.

# PE3W07349/PH90-24 CAD Drawing

SMA Female Bulkhead to Push-On SMP Female Right Angle Low Loss Cable Using LMR-100 Coax with 90 Deg. Clock in 24 Inch

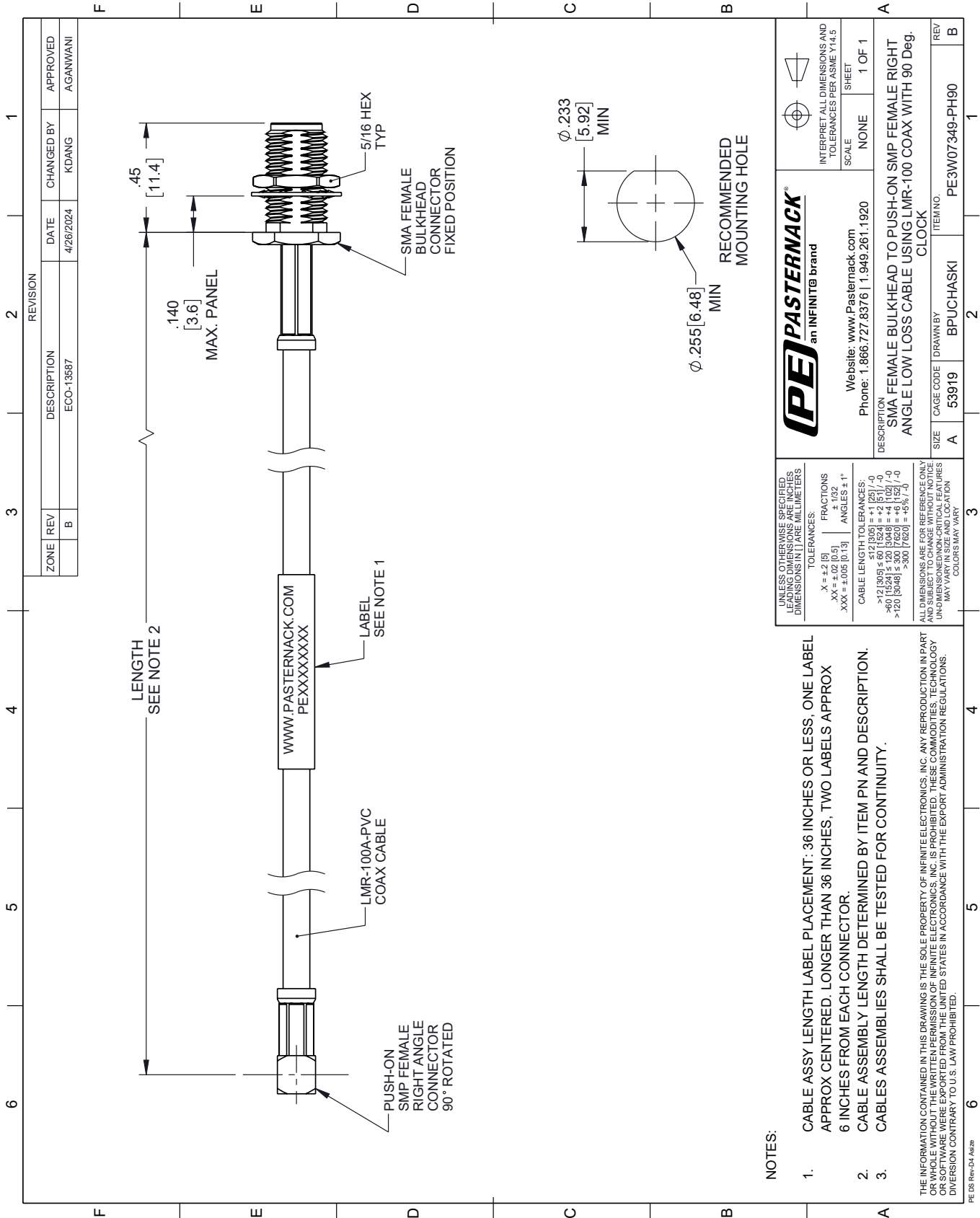

**NOTES:**

1. CABLE ASSY LENGTH LABEL PLACEMENT : 36 INCHES OR LESS, ONE LABEL APPROX CENTERED. LONGER THAN 36 INCHES, TWO LABELS APPROX 6 INCHES FROM EACH CONNECTOR.
2. CABLE ASSEMBLY LENGTH DETERMINED BY ITEM PN AND DESCRIPTION.
3. CABLES ASSEMBLIES SHALL BE TESTED FOR CONTINUITY.

THE INFORMATION CONTAINED IN THIS DRAWING IS THE SOLE PROPERTY OF INFINITE ELECTRONICS, INC. ANY REPRODUCTION IN PART OR WHOLE WITHOUT THE WRITTEN PERMISSION OF INFINITE ELECTRONICS, INC. IS PROHIBITED. THESE COMMODITIES, TECHNOLOGY OR SOFTWARE WERE EXPORTED FROM THE UNITED STATES IN ACCORDANCE WITH THE EXPORT ADMINISTRATION REGULATIONS. DIVERSION CONTRARY TO U.S. LAW PROHIBITED.

PE DS Rev-04 Add2

ZONE	REV	DESCRIPTION	DATE	CHANGED BY	APPROVED
B		ECO-13587	4/26/2024	KDANG	AGANWANI

		INTERPRET ALL DIMENSIONS AND TOLERANCES PER ASME Y14.5	
Website: <a href="http://www.Pasternack.com">www.Pasternack.com</a> Phone: 1.866.727.8376   1.949.261.1920		SCALE	NONE
DESCRIPTION SMA FEMALE BULKHEAD TO PUSH-ON SMP FEMALE RIGHT ANGLE LOW LOSS CABLE USING LMR-100 COAX WITH 90 DEG. CLOCK		SHEET	1 OF 1
SIZE	A	CAGE CODE	53919
DRAWN BY	BPUCHASKI	ITEM NO.	PE3W07349-PH90
REV	1		