



1.2 dB NF Input Protected Low Noise Amplifier, Operating from 900 MHz to 1.2 GHz with 40 dB Gain, 10 dBm P1dB and SMA

TECHNICAL DATA SHEET

PE15A63005

PE15A63005 is an Input Protected Low Noise RF coaxial amplifier operating in the 900 MHz to 1.2 GHz frequency range. The amplifier has a 1.2 dB typical noise figure and can handle up to 1 Watt CW input power without damage. Additional typical performance includes 40 dB small signal gain, 1.45:1 VSWR, and +10 dBm P1dB. The exceptional technical performance is achieved through the use of a 3 stage hybrid MIC assembly that incorporates a low loss input Pin Diode Limiter protective circuit followed by gain stages that use Enhancement Mode (Emode) GaAs pHEMT devices. The 50 Ohm SMA connectorized module is unconditionally stable, includes built-in DC voltage regulation, and supports DC blocking Capacitors on the RF ports. The Amplifier operates with a bias voltage of +12V typical and over the temperature range of -40°C to +75°C. This model is RoHS compliant and has an EAR99 export classification.

Features

- 900 MHz to 1.2 GHz Frequency Range
- P1dB: 10 dBm
- High Small Signal Gain: 40 dB typical
- Gain Flatness: ± 1 dB
- Noise Figure: 1.2 dB typ
- 50 Ohm Input and Output Matched
- -40°C to +75°C Operating Temperature
- Single DC Positive Supply
- DC Blocking Capacitors

Applications

- R&D Labs
- Radar Systems
- Test Instrumentation
- Communication Systems
- IF Amplifier/RF Driver Amplifier
- RF Wideband Front Ends

Electrical Specifications (TA = +25°C, DC Voltage = 12Vdc, DC Current = 100mA)

Description	Minimum	Typical	Maximum	Units
Frequency Range	0.9		1.2	GHz
Small Signal Gain		40		dB
Gain Flatness		± 1		dB
Gain Variance at OTR*		± 1.5		dB
Output at 1 dB Compression Point	+10			dBm
Noise Figure		1.2	1.4	dB
Input VSWR		1.5:1	1.8:1	
Output VSWR		1.4:1	1.6:1	
Spurious			-60	dBc
Input Power (CW)			+30	dBm
Operating DC Voltage		12		Volts
Operating DC Current		100		mA
Operating Temperature Range	-40		+75	°C

*OTR= Base Plate Operating Temperature Range

Click the following link (or enter part number in "SEARCH" on website) to obtain additional part information including price, inventory and certifications: [1.2 dB NF Input Protected Low Noise Amplifier, Operating from 900 MHz to 1.2 GHz with 40 dB Gain, 10 dBm P1dB and SMA PE15A63005](#)



1.2 dB NF Input Protected Low Noise Amplifier, Operating from 900 MHz to 1.2 GHz with 40 dB Gain, 10 dBm P1dB and SMA

TECHNICAL DATA SHEET

PE15A63005

Mechanical Specifications

Size

Length	1.5 in [38.1 mm]
Width	0.85 in [21.59 mm]
Height	0.375 in [9.53 mm]
Weight	0.053 lbs [24.04 g]
Input Connector	SMA Female
Output Connector	SMA Female

Environmental Specifications

Temperature

Operating Range	-40 to +75 deg C
Storage Range	-50 to +85 deg C

Compliance Certifications (see [product page](#) for current document)

Plotted and Other Data

Notes:

- Values at +25 °C, sea level

Click the following link (or enter part number in "SEARCH" on website) to obtain additional part information including price, inventory and certifications: [1.2 dB NF Input Protected Low Noise Amplifier, Operating from 900 MHz to 1.2 GHz with 40 dB Gain, 10 dBm P1dB and SMA PE15A63005](#)



1.2 dB NF Input Protected Low Noise Amplifier, Operating from 900 MHz to 1.2 GHz with 40 dB Gain, 10 dBm P1dB and SMA

TECHNICAL DATA SHEET

PE15A63005

Amplifier Power-up Precautions

- 1.) Confirm that proper ESD precautions and controls are always in place before handling any Amplifier module.
- 2.) Confirm adequate thermal management is in place to effectively dissipate heat away from the Amplifier package. The Amplifier operational baseplate temperature must be within the operational temperature range stated in the Amplifier datasheet. Depending on the design and thermal requirements, using a heatsink with cooling fan is always recommended for safe reliable operation. A heat sink without a cooling fan may also be used. Damage caused from overheating will void the warranty.
- 3.) Confirm adequate system grounding is established. The DC power supply and Amplifier must have a common ground in order to operate properly.
- 4.) Power Amplifiers may require additional DC Current when initially powered-up. Depending on the design, the input current draw could range from an additional 10% to 100% above the maximum rated DC current of the Amplifier. This varies based on product part number.
- 5.) Confirm the DC power supply, if limited, is set to allow for additional start-up current that's rated for the Power Amplifier.
- 6.) Confirm the system is designed and calibrated for 50 ohms. Any impedance mismatch may cause performance issues.
- 7.) Perform a CALIBRATION (if required) with the loads before connecting the Amplifier to the Network Analyzer to ensure proper performance.
- 8.) Use a fixed attenuator between the signal source and input port of the Amplifier to optimize the input VSWR match.
- 9.) Confirm the input power level at the input port of the amplifier does not exceed the maximum rated limit for input power (as stated in the Amplifier datasheet).
 P_{in} for Small Signal Gain = P1dB-SSG-10 dB
 P_{in} for P1dB = P1dB-SSG+1 dB
- 10.) Confirm the Network Analyzer is always connected to the Amplifier first before DC power is applied to the Amplifier.
- 11.) As long as the input and output ports of the amplifier are connected to a 50Ohm load and RF signal power is applied, the Amplifier can be powered up with DC voltage.
- 12.) Confirm the Amplifier output load is matched for a 50 Ohm impedance and will not exceed the maximum rated VSWR or Return Loss limit for the Amplifier. Exceeding the maximum rated VSWR or Return Loss limit will result in reflected signal power that could damage the Amplifier and void the warranty.
- 13.) **Power Amplifier connected to an Antenna for signal transmission** - It's strongly recommended to use a high power fixed attenuator pad or an Isolator between the output port of the Amplifier and input port to the antenna. Any reflected signal power due to impedance mismatch will likely damage the Amplifier and void the warranty.
- 14.) The attenuator or isolator used at the output port of the Amplifier must be rated to handle the output power level and operational frequency band of the amplifier.

Click the following link (or enter part number in "SEARCH" on website) to obtain additional part information including price, inventory and certifications: [1.2 dB NF Input Protected Low Noise Amplifier, Operating from 900 MHz to 1.2 GHz with 40 dB Gain, 10 dBm P1dB and SMA PE15A63005](#)



1.2 dB NF Input Protected Low Noise Amplifier, Operating from 900 MHz to 1.2 GHz with 40 dB Gain, 10 dBm P1dB and SMA

TECHNICAL DATA SHEET PE15A63005

Functional Block Diagram

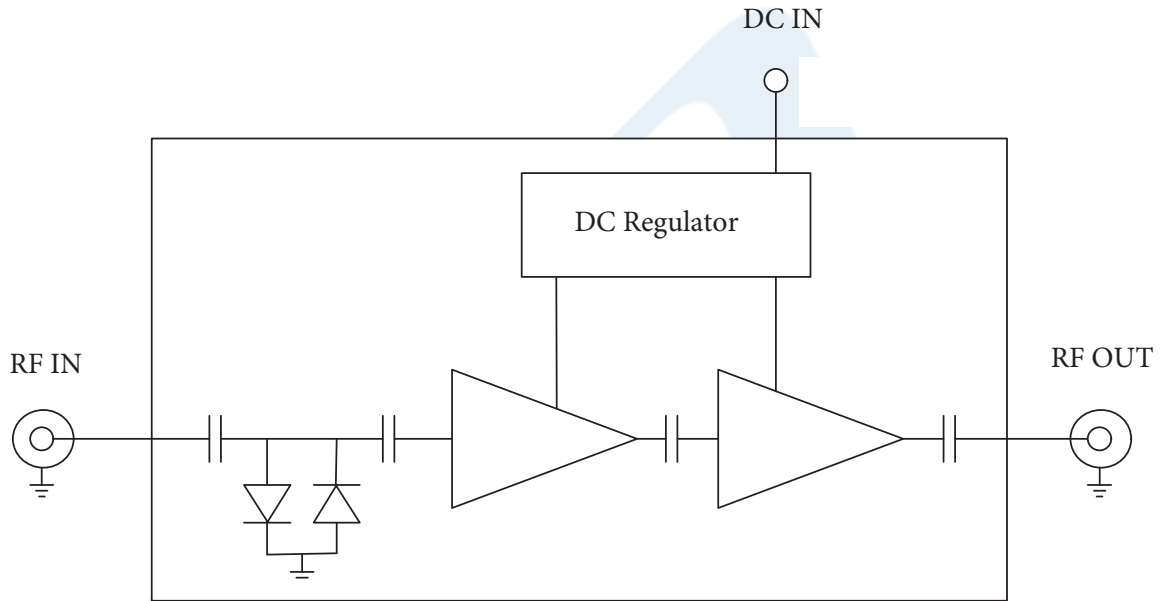

Typical Performance Data

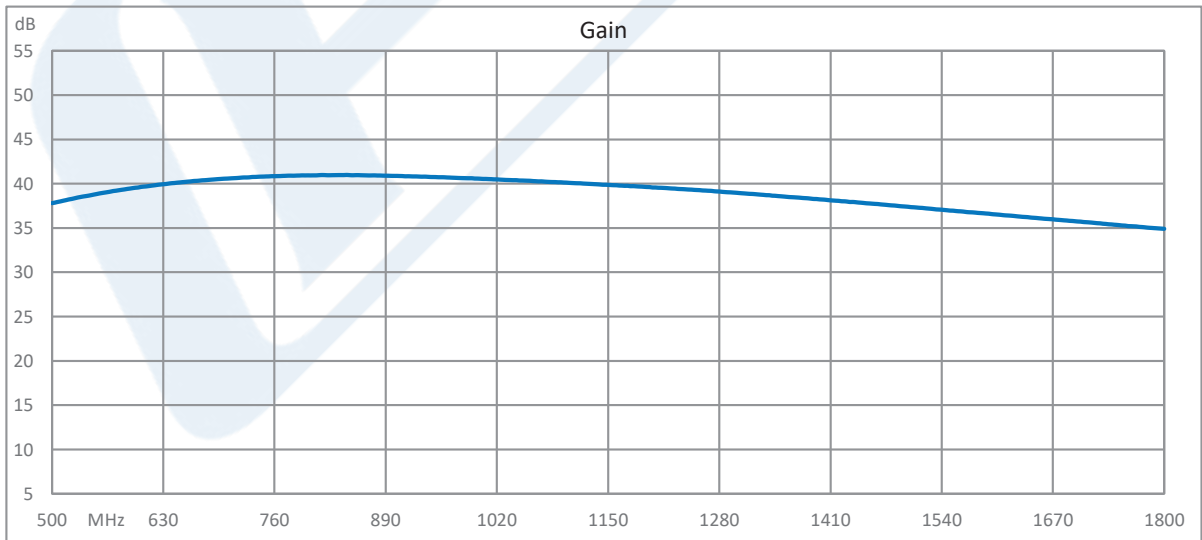

Click the following link (or enter part number in "SEARCH" on website) to obtain additional part information including price, inventory and certifications: [1.2 dB NF Input Protected Low Noise Amplifier, Operating from 900 MHz to 1.2 GHz with 40 dB Gain, 10 dBm P1dB and SMA PE15A63005](#)



1.2 dB NF Input Protected Low Noise Amplifier, Operating from 900 MHz to 1.2 GHz with 40 dB Gain, 10 dBm P1dB and SMA

TECHNICAL DATA SHEET

PE15A63005

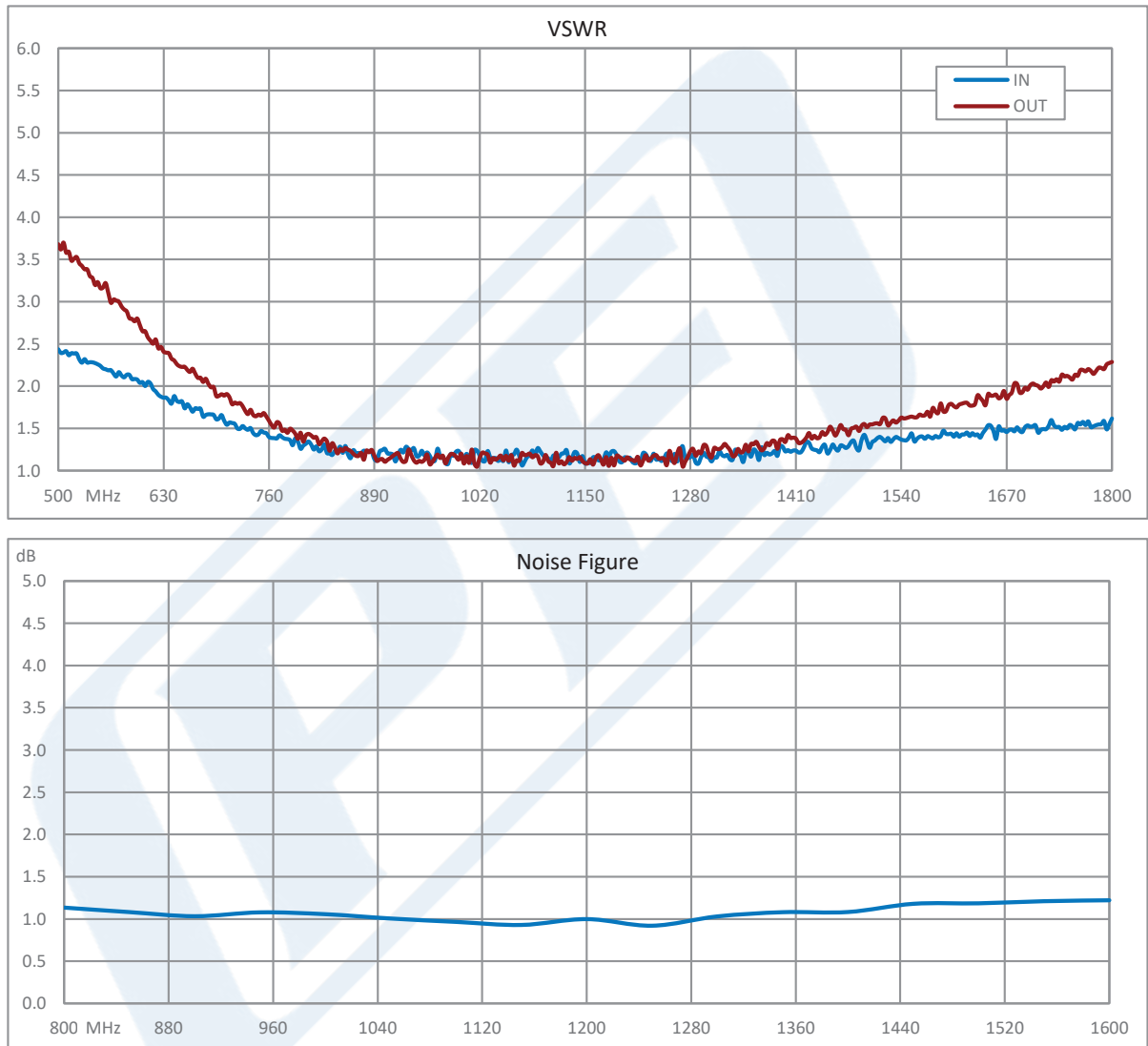

Click the following link (or enter part number in "SEARCH" on website) to obtain additional part information including price, inventory and certifications: [1.2 dB NF Input Protected Low Noise Amplifier, Operating from 900 MHz to 1.2 GHz with 40 dB Gain, 10 dBm P1dB and SMA PE15A63005](#)



1.2 dB NF Input Protected Low Noise Amplifier, Operating from 900 MHz to 1.2 GHz with 40 dB Gain, 10 dBm P1dB and SMA

TECHNICAL DATA SHEET

PE15A63005

1.2 dB NF Input Protected Low Noise Amplifier, Operating from 900 MHz to 1.2 GHz with 40 dB Gain, 10 dBm P1dB and SMA from Pasternack Enterprises has same day shipment for domestic and International orders. Our RF, microwave and millimeter wave products maintain a 99.4% availability and are part of the broadest selection in the industry.

Click the following link (or enter part number in "SEARCH" on website) to obtain additional part information including price, inventory and certifications: [1.2 dB NF Input Protected Low Noise Amplifier, Operating from 900 MHz to 1.2 GHz with 40 dB Gain, 10 dBm P1dB and SMA PE15A63005](#)

URL: <https://www.pasternack.com/40-db-gain-1.2-db-1.2-ghz-low-noise-amplifier-sma-pe15a63005-p.aspx>

The information contained in this document is accurate to the best of our knowledge and representative of the part described herein. It may be necessary to make modifications to the part and/or the documentation of the part, in order to implement improvements. Pasternack reserves the right to make such changes as required. Unless otherwise stated, all specifications are nominal. Pasternack does not make any representation or warranty regarding the suitability of the part described herein for any particular purpose, and Pasternack does not assume any liability arising out of the use of any part or documentation.

PE15A63005 CAD Drawing

1.2 dB NF Input Protected Low Noise Amplifier, Operating from 900 MHz to 1.2 GHz with 40 dB Gain, 10 dBm P1dB and SMA

REVISIONS			
REV.	DESCRIPTION	DATE	APPROVED
A	INITIAL RELEASE	08/26/19	J.GARCIA

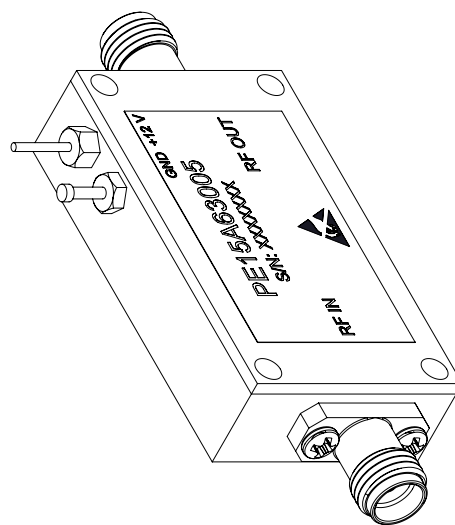
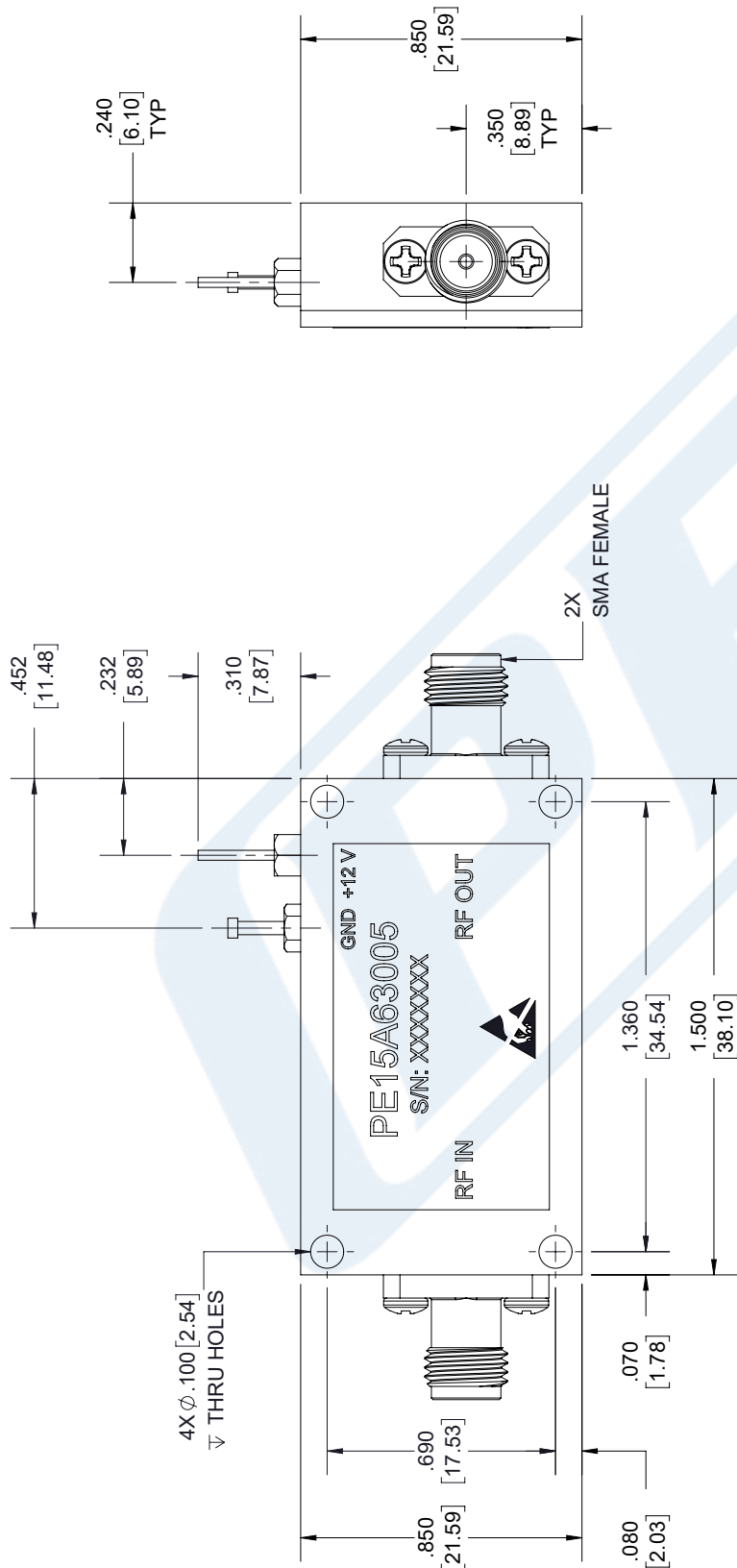

UNLESS OTHERWISE SPECIFIED LEADING DIMENSIONS ARE INCHES DIMENSIONS IN [] ARE MILLIMETERS	
TOLERANCES:	FRACTIONS
X±.2 [5.08]	±.132
.XX±.01 [.25]	±.132
.XXX±.005 [.13]	ANGLES ± 1°
ALL DIMENSIONS SHOWN ARE FOR REFERENCE ONLY.	
THIRD-ANGLE PROJECTION	

PE PASTERNAK
an INFINITO brand

Pasternack Enterprises, Inc.
P.O. Box 16759, Irvine, CA 92623.
Phone: 1.949.261.1920 | 1.866.727.8376
Fax: 1.949.261.7451
www.pasternack.com | e-mail: sales@pasternack.com

THE INFORMATION AND DESIGN IN THIS DOCUMENT IS THE PROPERTY OF PASTERNAK CORPORATION. ALL RIGHTS RESERVED.

SHEET 1 OF 1
SCALE N/A

SIZE A
CAGE 53919
DRAWN BY K.DANG
PART NUMBER PE15A63005
REV A

THESE COMMODITIES, TECHNOLOGY OR SOFTWARE WERE EXPORTED FROM THE UNITED STATES IN ACCORDANCE WITH THE EXPORT ADMINISTRATION REGULATIONS. DIVERSION CONTRARY TO U.S. LAW PROHIBITED.