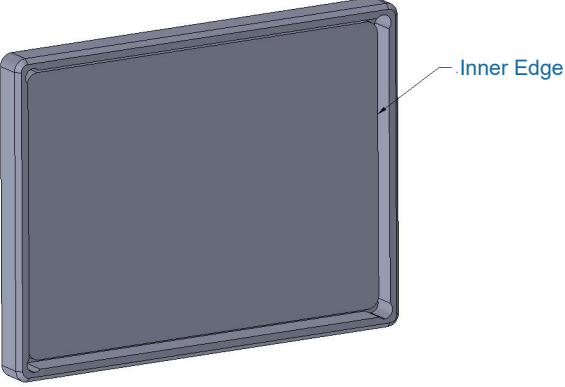
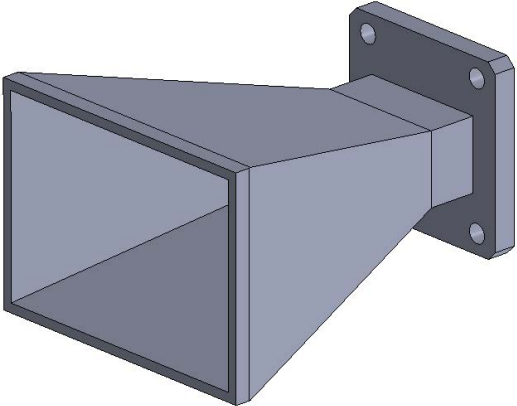
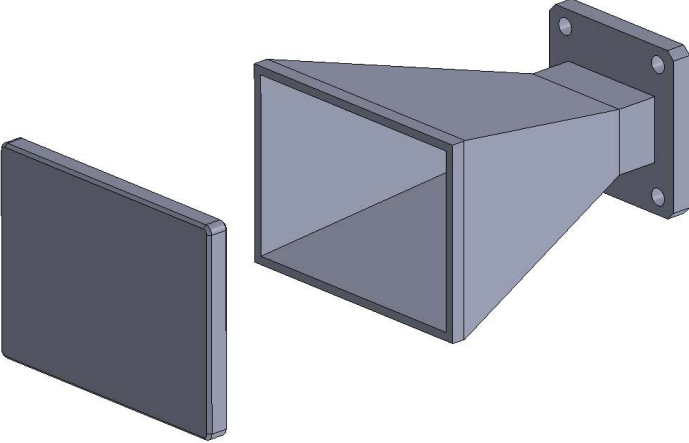
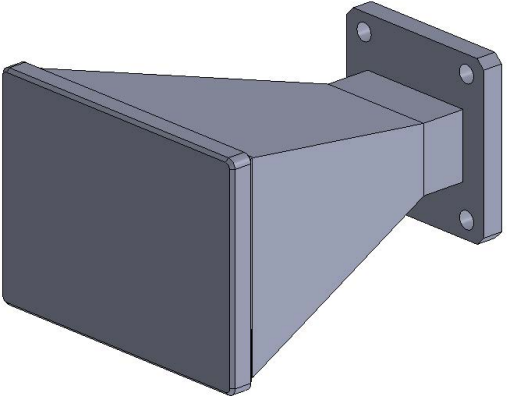

Materials Needed:

1. Pasternack Standard Gain Horn Radome Cover
2. Matching Standard Gain Horn Size (not included)
3. 3M Scotch-Weld™ Epoxy Adhesive DP420 or equivalent (not included)
4. Appropriate Epoxy Applicator (not included)

INSTALLATION INSTRUCTIONS

<p>Radome Cover</p> 	<p>Antenna</p> 
<p>1. Apply a bead of epoxy to the inner edge of the radome cover.</p>	
	
<p>2. Press the cover to the antenna opening.</p>	<p>3. Allow to cure for a minimum of 30 minutes or as recommended by the instructions provided by the epoxy brand.</p>

PHOTOS FOR REFERENCE

